

【製品名・図番対応表】

2011/4/4

製品名	材質	寸法	図番	備考
CUプレス				
銅品 90CE		15	ZA4-085-1	寸法記号の見直し
銅品 90CE		20	ZA4-085-1	寸法記号の見直し
銅品 90CE		25	ZA4-085-1	寸法記号の見直し
銅品 90E		10	ZA4-047-2	寸法記号の見直し
銅品 90E		15	ZA4-048-2	寸法記号の見直し
銅品 90E		20	ZA4-048-2	寸法記号の見直し
銅品 90E		25	ZA4-048-2	寸法記号の見直し
銅品 90E		20X15	ZA4-074-1	寸法記号の見直し
銅品 S		10	ZA4-051-2	寸法記号の見直し
銅品 S		15	ZA4-052-2	寸法記号の見直し
銅品 S		20	ZA4-052-2	寸法記号の見直し
銅品 S		25	ZA4-052-2	寸法記号の見直し
銅品 T		15	ZA4-031-2	寸法記号の見直し
銅品 T		20	ZA4-031-2	寸法記号の見直し
銅品 T		20X15	ZA4-031-2	寸法記号の見直し
銅品 T		25	ZA4-031-2	寸法記号の見直し
銅品 T		25X20	ZA4-031-2	寸法記号の見直し
銅品 45E		15	ZA4-049-2	寸法記号の見直し
銅品 45E		20	ZA4-049-2	寸法記号の見直し
銅品 45E		25	ZA4-049-2	寸法記号の見直し
銅品 R		15X10	ZA4-034-2	寸法記号の見直し
銅品 R		20X15	ZA4-034-2	寸法記号の見直し
銅品 R		25X20	ZA4-034-2	寸法記号の見直し
銅品 BS		15	ZA4-070-2	寸法記号の見直し
銅品 BS		20	ZA4-070-2	寸法記号の見直し
銅品 BS		25	ZA4-070-2	寸法記号の見直し
銅品 ASオス		15X1/2	ZA4-027-1	寸法記号の見直し
銅品 ASオス		20X3/4	ZA4-027-1	寸法記号の見直し
銅品 ASオス		25X1	ZA4-027-1	寸法記号の見直し
銅品 ASメス		15X1/2	ZA4-032-1	寸法記号の見直し
銅品 ASメス		20X3/4	ZA4-032-1	寸法記号の見直し
銅品 ASメス		25X1	ZA4-032-1	寸法記号の見直し
銅品 水栓E(ショート)		15X1/2	ZA4-028-2	ネジ表記の見直し
銅品 水栓E(ショート)		20X1/2	ZA4-029-3	ネジ表記の見直し
銅品 水栓E(ショート)		20X3/4	ZA4-030-3	ネジ表記の見直し
銅品 水栓S		15X1/2	ZA4-043-3	ネジ表記の見直し
銅品 水栓S		20X1/2	ZA4-043-3	ネジ表記の見直し
銅品 水栓S		20X3/4	ZA4-043-3	ネジ表記の見直し
銅品 水栓T		15X1/2	ZA4-072-2	ネジ表記の見直し
銅品 座付水栓E		15X1/2	ZA4-033-2	ネジ表記の見直し
銅品 腰高座付水栓E		15X1/2	ZA4-046-3	ネジ表記の見直し
銅品 逆座付水栓E		15X1/2	ZA4-063-3	ネジ表記の見直し
銅品 座付水栓S		15X1/2	ZA4-060-2	ネジ表記の見直し
銅品 逆座付水栓S		15X1/2	ZA4-064-2	ネジ表記の見直し
銅品 水栓E(ショート)直管付		15X1/2	ZA4-056-3	ネジ表記の見直し
銅品 水栓E(ショート)直管付		20X1/2	ZA4-056-3	ネジ表記の見直し
銅品 水栓E(ショート)直管付		20X3/4	ZA4-056-3	ネジ表記の見直し
銅品 座付水栓E 直管付		15X1/2	ZA4-059-3	ネジ表記の見直し
銅品 90°ユニオン		10X1/2	ZA4-054-1	寸法記号の見直し
銅品 90°ユニオン		15X1/2	ZA4-035-1	寸法記号の見直し
銅品 90°ユニオン		15X3/4	ZA4-035-1	寸法記号の見直し
銅品 90°ユニオン		20X1/2	ZA4-035-1	寸法記号の見直し
銅品 90°ユニオン		20X3/4	ZA4-035-1	寸法記号の見直し

受注番号 Order No.		材料 Material	C1220T	数量 Quantity	
-------------------	--	----------------	--------	----------------	--

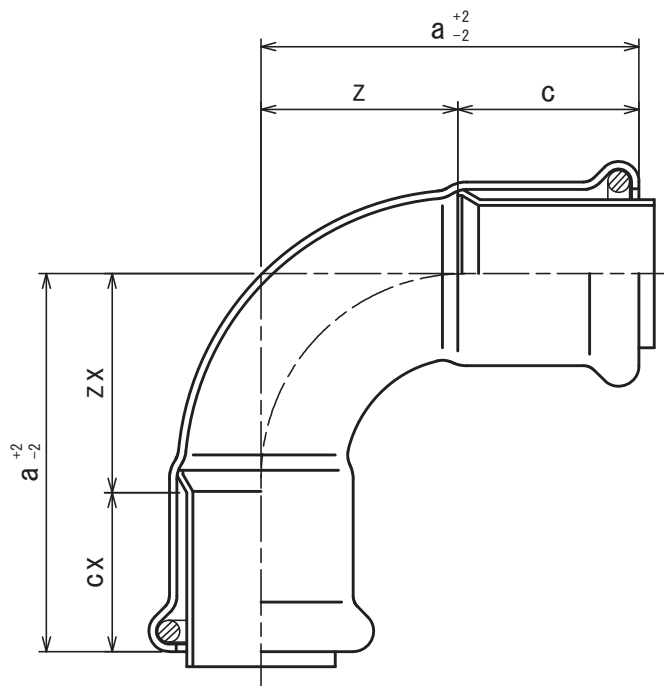

記号 サイズ(A)	a	z	c	ZX	CX
15	41	20	21	23	18
20	50	26	24	29	21
25	54	30	24	33	21

ALL DIMENSIONS ARE IN MILLIMETERS.

尺 度 SCALE		品 名 DESCRIPTION					
N. T. S		CUプレス 90°コンパクトエルボ 15, 20, 25A		1	寸法記号の見直し	H20.02.05	谷藤
発行 ISSUED BY	作成 PREPARED BY			改訂 Rev.	改訂内容 DESCRIPTION	発行 ISSUED BY	作成 PREPARED BY
勅使川原	山藤			寸法規格 DIMENSIONAL STANDARD		図面番号 DRAWING No.	
						ZA4-085	
						Rev. No. — 1	

株式会社ベンカン・ジャパン

受注番号 Order No.		材料 Material	C1220T	数量 Quantity	
-------------------	--	----------------	--------	----------------	--

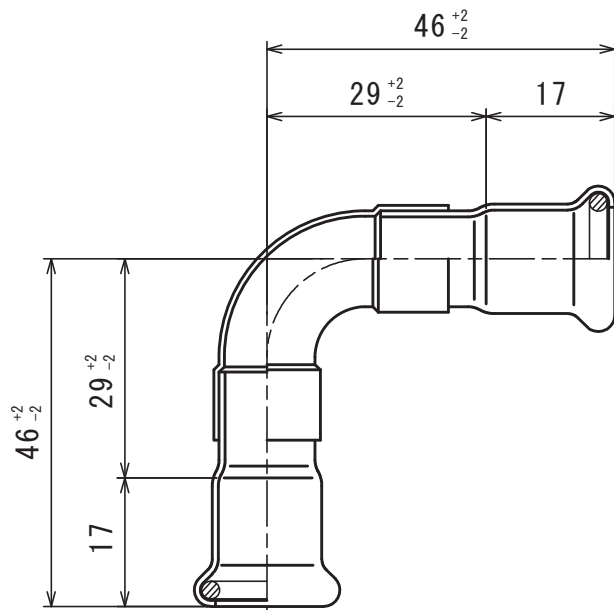

ALL DIMENSIONS ARE IN MILLIMETERS.

尺度 SCALE		品名 DESCRIPTION		3	90° エルボ形状変更 寸法記号の見直し 図番変更	H21.07.08	山藤
N. T. S		CUプレス ろう付タイプ 90° エルボ 10A		2		H20.02.05	谷藤
発行 ISSUED BY	作成 PREPARED BY			1		H14.02.20	山藤
		改訂 Rev.	改訂内容 DESCRIPTION	発行 ISSUED BY	作成 PREPARED BY		
		寸法 DIMENSIONAL	規格 STANDARD	図面番号 DRAWING No.			
				ZA4-047		Rev. No. — 3	

受注番号 Order No.		材料 Material	C1220T	数量 Quantity	
-------------------	--	----------------	--------	----------------	--

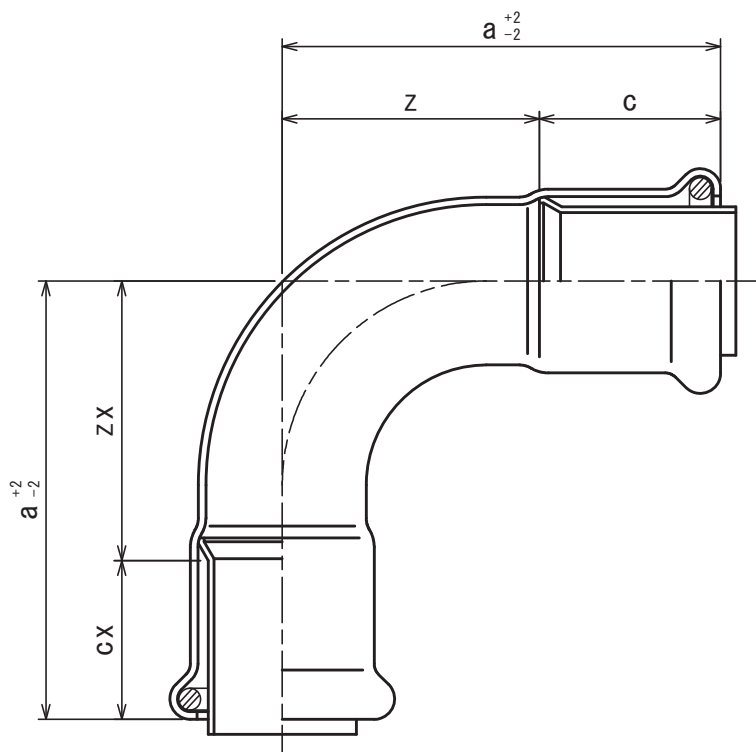

記号 サイズ(A)	a	z	c	ZX	CX
15	48	27	21	30	18
20	58	34	24	37	21
25	66	42	24	45	21

ALL DIMENSIONS ARE IN MILLIMETERS.

尺度 SCALE		品名 DESCRIPTION		2	寸法記号の見直し 図番変更	H20.02.05	谷藤
N. T. S		CUプレス		1		H14.02.20	山藤
発行 ISSUED BY	作成 PREPARED BY	90°エルボ 15, 20, 25A		改訂 Rev.	改訂内容 DESCRIPTION	発行 ISSUED BY	作成 PREPARED BY
勅使川原	山藤	寸法 DIMENSIONAL	規格 STANDARD	図面番号 DRAWING No.		ZA4-048	
						Rev. No.	— 2

株式会社ベンカン・ジャパン

受注番号 Order No.		材料 Material	C1220T	数量 Quantity	
-------------------	--	----------------	--------	----------------	--

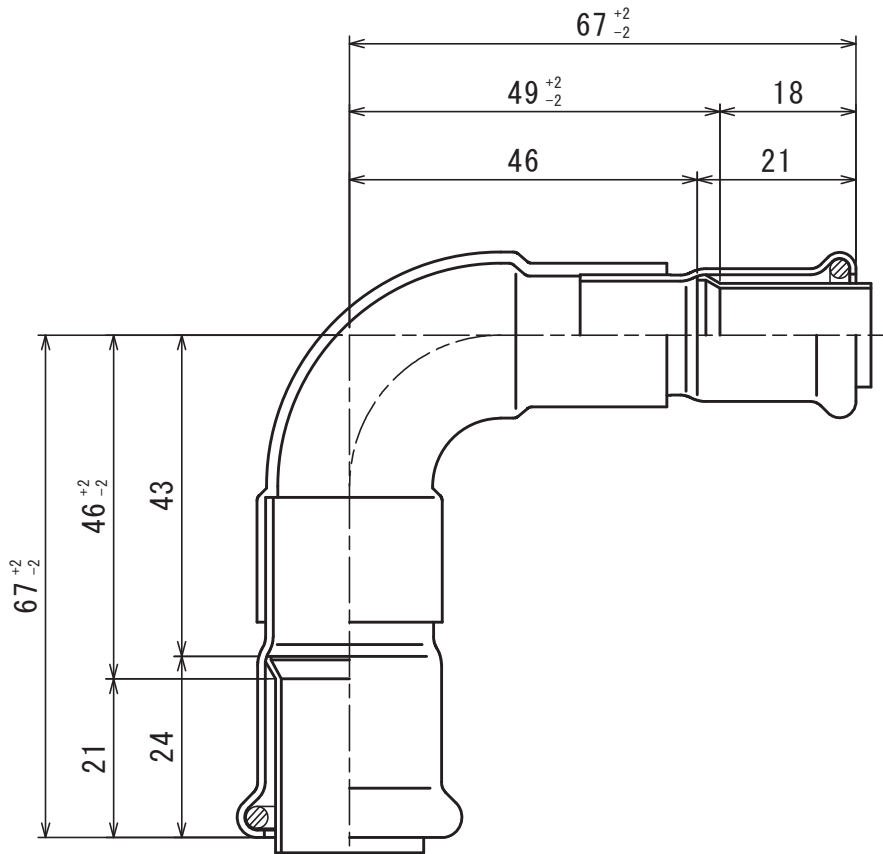

ALL DIMENSIONS ARE IN MILLIMETERS.

尺度 SCALE		品名 DESCRIPTION					
N. T. S		CUプレス ろう付タイプ 90°エルボ 20A×15A		1	寸法記号の見直し	H20.02.05	谷藤
発行 ISSUED BY	作成 PREPARED BY	改訂 Rev.	改訂内容 DESCRIPTION	発行 ISSUED BY	作成 PREPARED BY		
勅使川原	山藤	寸法 DIMENSIONAL	規格 STANDARD	図面番号 DRAWING No.		Rev. No.	
				ZA4-074		— 1	

株式会社ベンカン・ジャパン

受注番号 Order No.		材料 Material	C1220T	数量 Quantity	
-------------------	--	----------------	--------	----------------	--

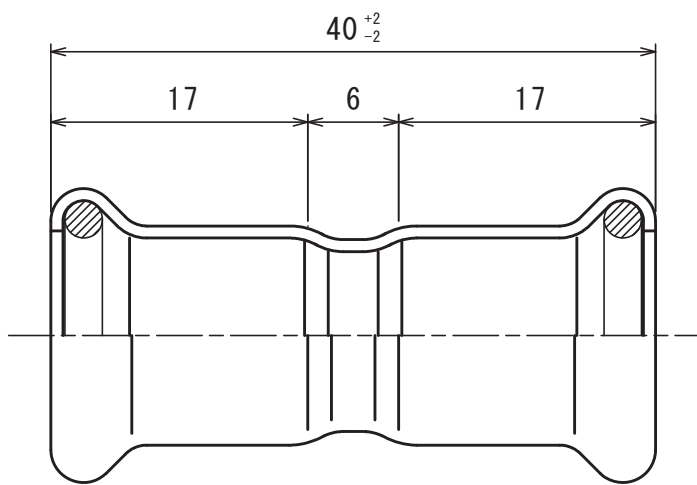

ALL DIMENSIONS ARE IN MILLIMETERS.

尺度 SCALE		品名 DESCRIPTION					
N. T. S		CUプレス ソケット 10A		2 1	寸法記号の見直し 図番変更	H20.02.05 H14.02.20	谷藤 山藤
発行 ISSUED BY	作成 PREPARED BY			改訂 Rev.	改訂内容 DESCRIPTION	発行 ISSUED BY	作成 PREPARED BY
勅使川原	山藤			寸法規格 DIMENSIONAL STANDARD	図面番号 DRAWING No.	ZA4-051	

株式会社ベンカン・ジャパン

受注番号 Order No.		材料 Material	C1220T	数量 Quantity	
-------------------	--	----------------	--------	----------------	--

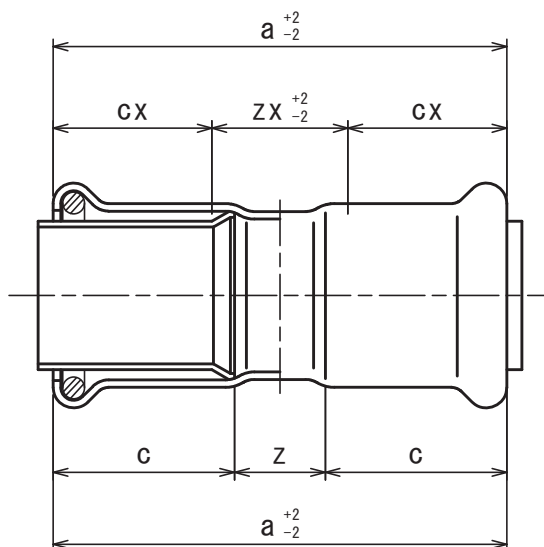

記号 サイズ(A)	a	Z	C	ZX	CX
15	53	11	21	17	18
20	60	12	24	18	21
25	60	12	24	18	21

ALL DIMENSIONS ARE IN MILLIMETERS.

尺度 SCALE		品名 DESCRIPTION									
N. T. S		CUプレス ソケット 15, 20, 25A		2 1		寸法記号の見直し 図番変更		H20.02.05 H14.02.20		谷藤 山藤	
発行 ISSUED BY	作成 PREPARED BY			改訂 Rev.	改訂内容 DESCRIPTION			発行 ISSUED BY	作成 PREPARED BY		
勅使 川原	山 藤			寸法規格 DIMENSIONAL STANDARD		図面番号 DRAWING No.					
				ZA4-052				Rev. No. — 2			

株式会社ベンカン・ジャパン

受注番号 Order No.		材料 Material	C1220T	数量 Quantity	
-------------------	--	----------------	--------	----------------	--

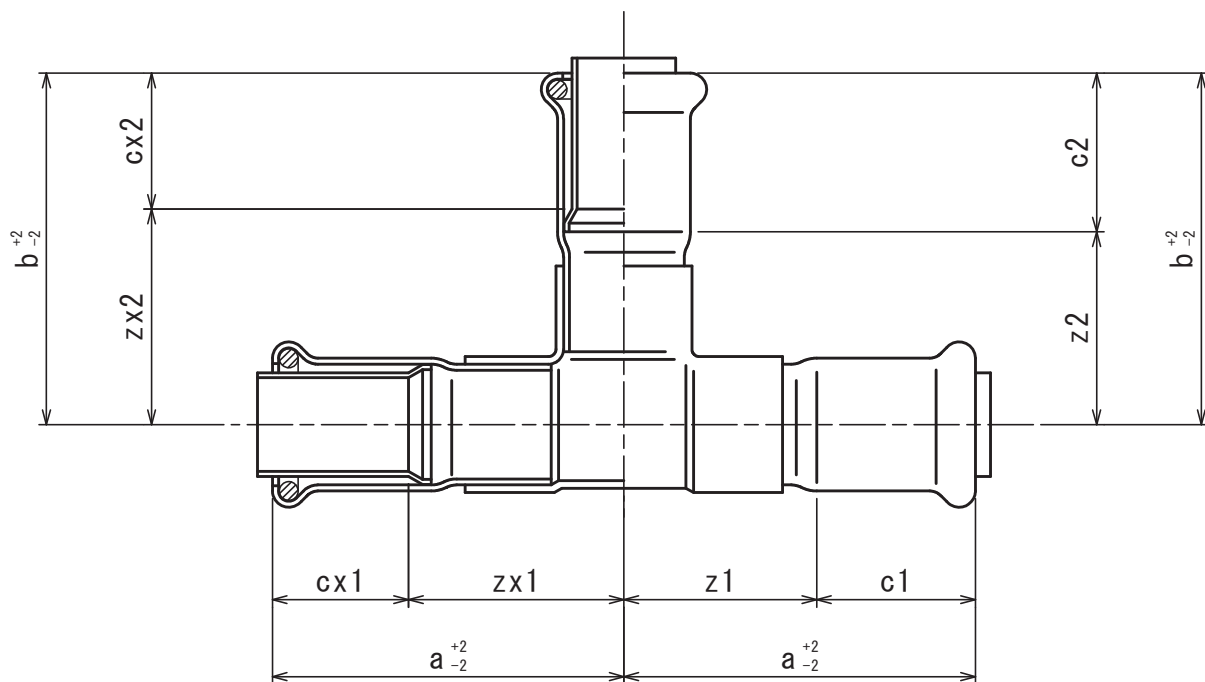

記号 サイズ(A)	a	b	z1	z2	c1	c2	zx1	zx2	cx1	cx2
15	47	47	26	26	21	21	29	29	18	18
20	59	59	35	35	24	24	38	38	21	21
20x15	58	51	34	30	24	21	37	33	21	18
25	67	67	43	43	24	24	46	46	21	21
25x20	64	64	40	40	24	24	43	43	21	21

ALL DIMENSIONS ARE IN MILLIMETERS.

尺度 SCALE		品名 DESCRIPTION		2 1	寸法記号の見直し 20A, 25A追加	H20.02.05 H16.06.10	谷藤 山藤
N. T. S		CUプレス ろう付タイプ ティー 15, 20, 25A		改訂 Rev.	改訂内容 DESCRIPTION	発行 ISSUED BY	作成 PREPARED BY
発行 ISSUED BY	作成 PREPARED BY			寸法規格 DIMENSIONAL STANDARD	図面番号 DRAWING No.		
勅使川原	山藤			ZA4-031		Rev. No. — 2	

株式会社ベンカン・ジャパン

受注番号 Order No.		材料 Material	C1220T	数量 Quantity	
-------------------	--	----------------	--------	----------------	--

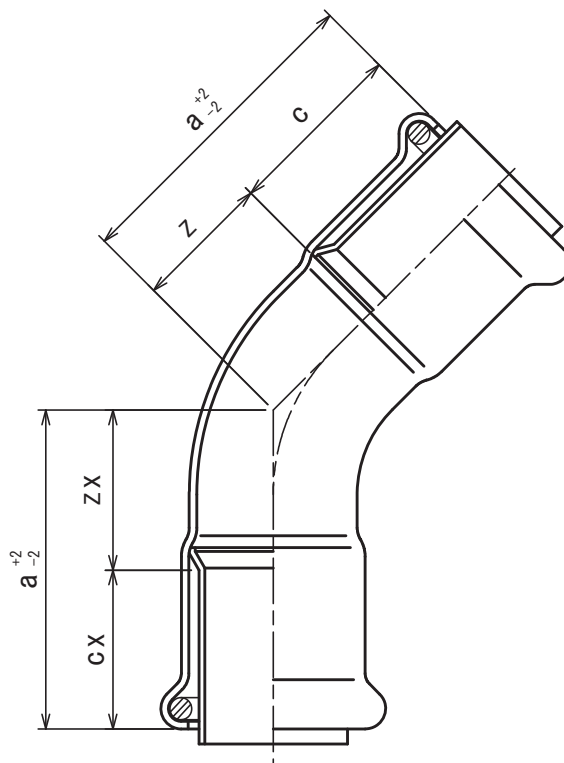

記号 サイズ(A)	a	z	c	ZX	CX
15	36	15	21	18	18
20	42	18	24	21	21
25	46	22	24	25	21

ALL DIMENSIONS ARE IN MILLIMETERS.

尺度 SCALE		品名 DESCRIPTION					
N. T. S		CUプレス 45°エルボ 15, 20, 25A		2 1	寸法記号の見直し 図番変更	H20.02.05 H14.02.20	谷藤 山藤
発行 ISSUED BY	作成 PREPARED BY			改訂 Rev.	改訂内容 DESCRIPTION	発行 ISSUED BY	作成 PREPARED BY
勅使川原	山藤			寸法 DIMENSIONAL	規格 STANDARD	図面番号 DRAWING No.	
				ZA4-049		Rev. No. — 2	

株式会社ベンカン・ジャパン

受注番号 Order No.		材料 Material	C1220T	数量 Quantity	
-------------------	--	----------------	--------	----------------	--

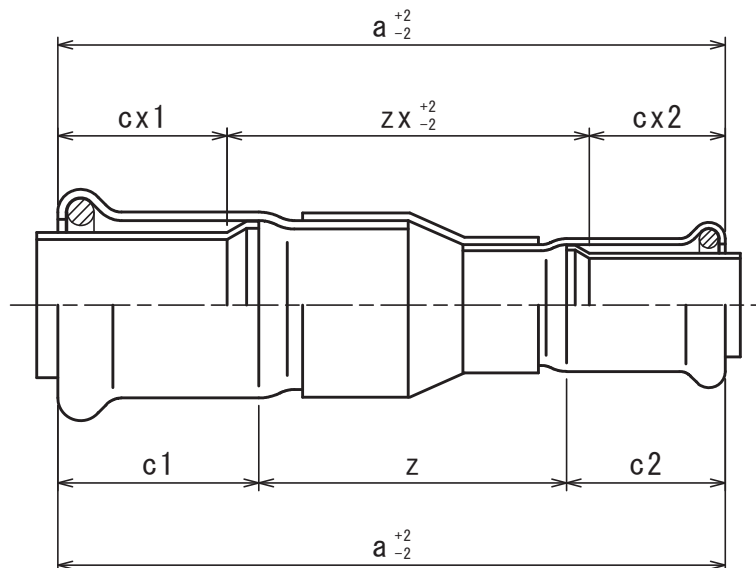

記号 サイズ(A)	a	z	c1	c2	zx	cx1	cx2
15x10	71	33	21	17	36	18	17
20x15	91	46	24	21	52	21	18
25x20	107	59	24	24	65	21	21

ALL DIMENSIONS ARE IN MILLIMETERS.

尺度 SCALE		品名 DESCRIPTION					
N. T. S		CUプレス ろう付タイプ レジャーサ		2 1 寸法記号の見直し 15A×10A追加		H20.02.05 H16.06.10	
発行 ISSUED BY	作成 PREPARED BY	15A×10A, 20A×15A, 25A×20A		改訂 Rev.		改訂内容 DESCRIPTION	
勅使川原	山藤			寸法規格 DIMENSIONAL STANDARD		図面番号 DRAWING No.	
						ZA4-034	
						Rev. No. — 2	

株式会社ベンカン・ジャパン

受注番号 Order No.		材 料 Material	C1220T	数 量 Quantity	
-------------------	--	-----------------	--------	-----------------	--

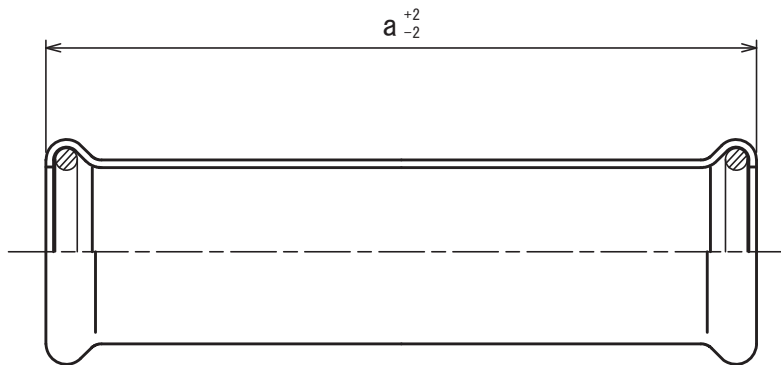

記号 サイズ (A)	a
15	115
20	128
25	128

ALL DIMENSIONS ARE IN MILLIMETERS.

尺 度 SCALE		品 名 DESCRIPTION		2	寸法記号の見直し 図番変更	H20.02.05 H14.02.20	谷藤 山藤
N. T. S		CUプレス ベアソケット 15A, 20A, 25A		1			
発行 ISSUED BY	作成 PREPARED BY			改訂 Rev.	改訂内容 DESCRIPTION	発行 ISSUED BY	作成 PREPARED BY
勅使川原	山藤			寸法規格 DIMENSIONAL STANDARD		図面番号 DRAWING No.	
				ZA4-070		Rev. No. — 2	

株式会社ベンカン・ジャパン

受注番号 Order No.		材料 Material	C1220T	数量 Quantity	
-------------------	--	----------------	--------	----------------	--

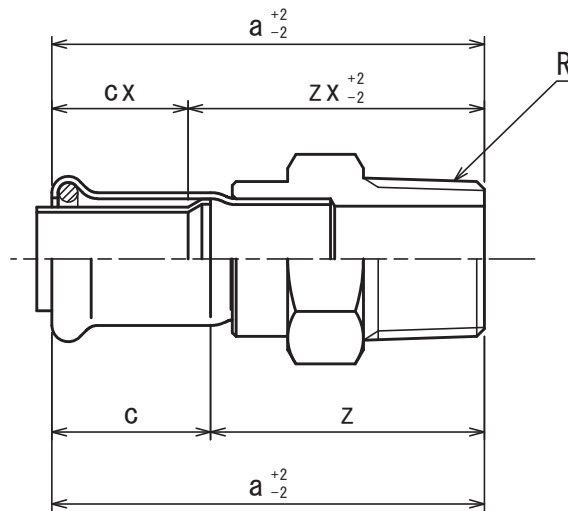

記号 サイズ(A)	a	z	c	ZX	CX	R	
						呼び	ねじ山数 (25.4mm)
15 × 1/2	55.5	34.5	21	37.5	18	1/2	14
20 × 3/4	68.5	44.5	24	47.5	21	3/4	14
25 × 1	73.0	49.0	24	52.0	21	1	11

ALL DIMENSIONS ARE IN MILLIMETERS.

尺度 SCALE		品名 DESCRIPTION						
N. T. S		CUプレス ろう付タイプ 雄アダプタ付ソケット 15A, 20A, 25A		1	寸法記号の見直し	H20.02.05	谷藤	
発行 ISSUED BY	作成 PREPARED BY			改訂 Rev.	改訂内容 DESCRIPTION	発行 ISSUED BY	作成 PREPARED BY	
勅使川原	山藤			寸法 DIMENSIONAL	規格 STANDARD	図面番号 DRAWING No.		Rev. No. — 1
				ZA4-027				

株式会社ベンカン・ジャパン

受注番号 Order No.		材料 Material	C1220T	数量 Quantity	
-------------------	--	----------------	--------	----------------	--

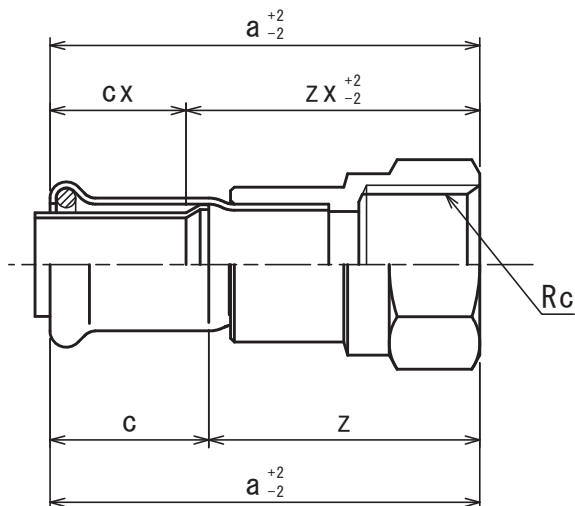

記号 サイズ(A)	a	z	c	zx	cx	Rc	
						呼び	ねじ山数 (25.4mm)
15 × 1/2	57	36	21	39	18	1/2	14
20 × 3/4	73	49	24	52	21	3/4	14
25 × 1	75	51	24	54	21	1	11

ALL DIMENSIONS ARE IN MILLIMETERS.

尺度 SCALE		品名 DESCRIPTION						
N. T. S		CUプレス ろう付タイプ 雌アダプタ付ソケット 15A, 20A, 25A		1	寸法記号の見直し	H20.02.05	谷藤	
発行 ISSUED BY	作成 PREPARED BY			改訂 Rev.	改訂内容 DESCRIPTION	発行 ISSUED BY	作成 PREPARED BY	
勅使川原	山藤			寸法 DIMENSIONAL	規格 STANDARD	図面番号 DRAWING No.		
				ZA4-032		Rev. No. — 1		

株式会社ベンカン・ジャパン

受注番号 Order No.		材料 Material	BC6 C1220T	数量 Quantity	
-------------------	--	----------------	---------------	----------------	--

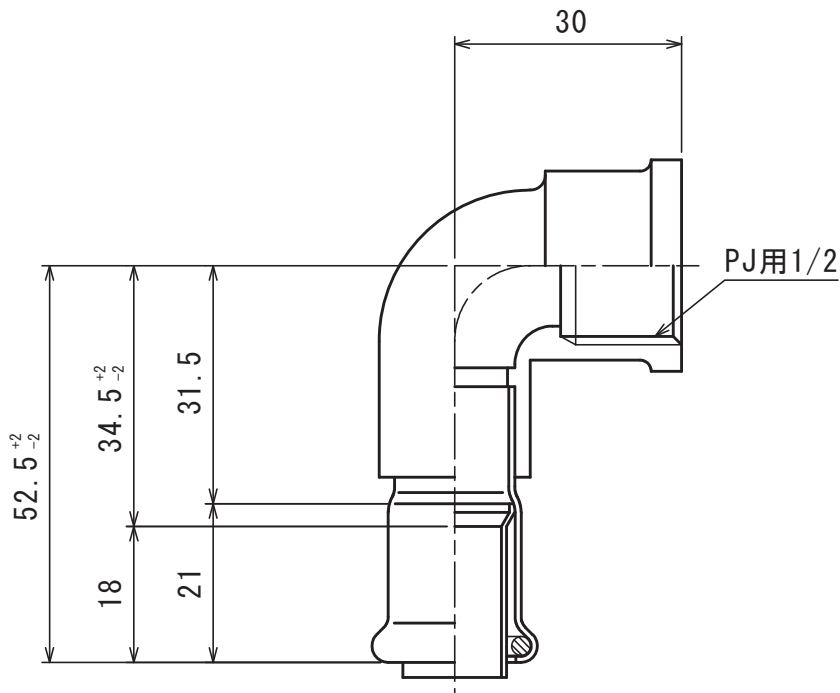

ALL DIMENSIONS ARE IN MILLIMETERS.

尺度 SCALE		品名 DESCRIPTION					
N. T. S		CUプレス ろう付タイプ 水栓エルボ 15A×1/2		2	寸法表記の見直し 寸法記号の見直し	H23.04.04 H20.02.05	山藤 谷藤
発行 ISSUED BY	作成 PREPARED BY			改訂 Rev.			
垣上	山藤	寸法 DIMENSIONAL	規格 STANDARD	図面番号 DRAWING No.		Rev. No. — 2	
				ZA4-028			

受注番号 Order No.		材料 Material	BC6 C1220T	数量 Quantity	
-------------------	--	----------------	---------------	----------------	--

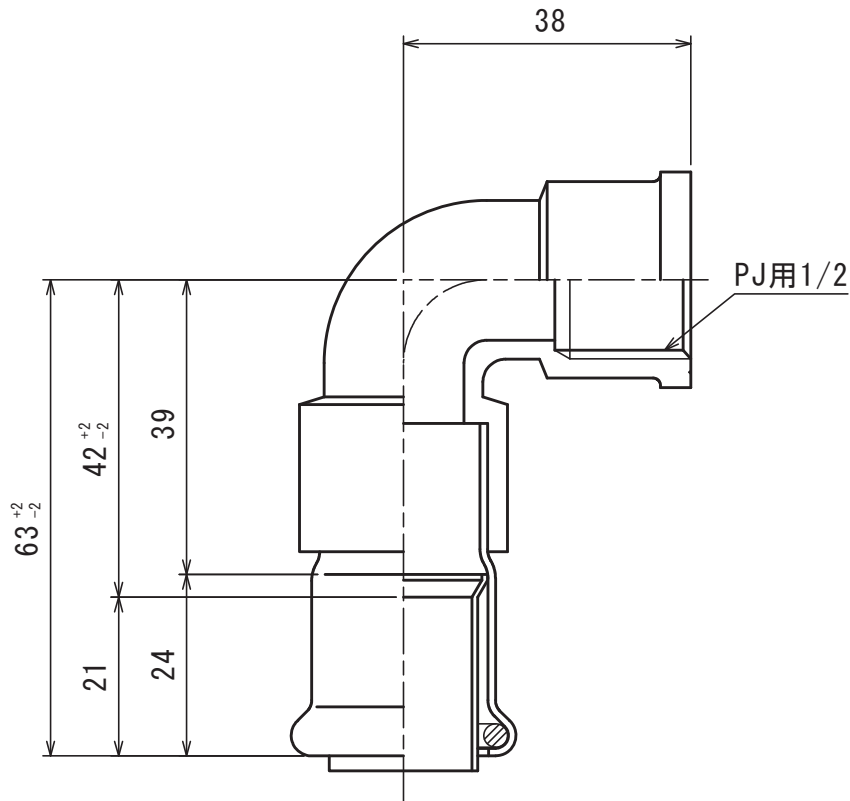

ALL DIMENSIONS ARE IN MILLIMETERS.

尺度 SCALE		品名 DESCRIPTION		3	寸法表記の見直し 寸法記号の見直し 寸法見直し	H23.04.04 H20.02.05 H14.02.20	山藤 谷藤 山藤
N. T. S		CUプレス ろう付タイプ 水栓エルボ 20A×1/2		2			
発行 ISSUED BY	作成 PREPARED BY			1			
垣上	山藤	寸法 DIMENSIONAL	規格 STANDARD	図面番号 DRAWING No.		Rev. No. — 3	
				ZA4-029			

受注番号 Order No.		材料 Material	BC6 C1220T	数量 Quantity	
-------------------	--	----------------	---------------	----------------	--

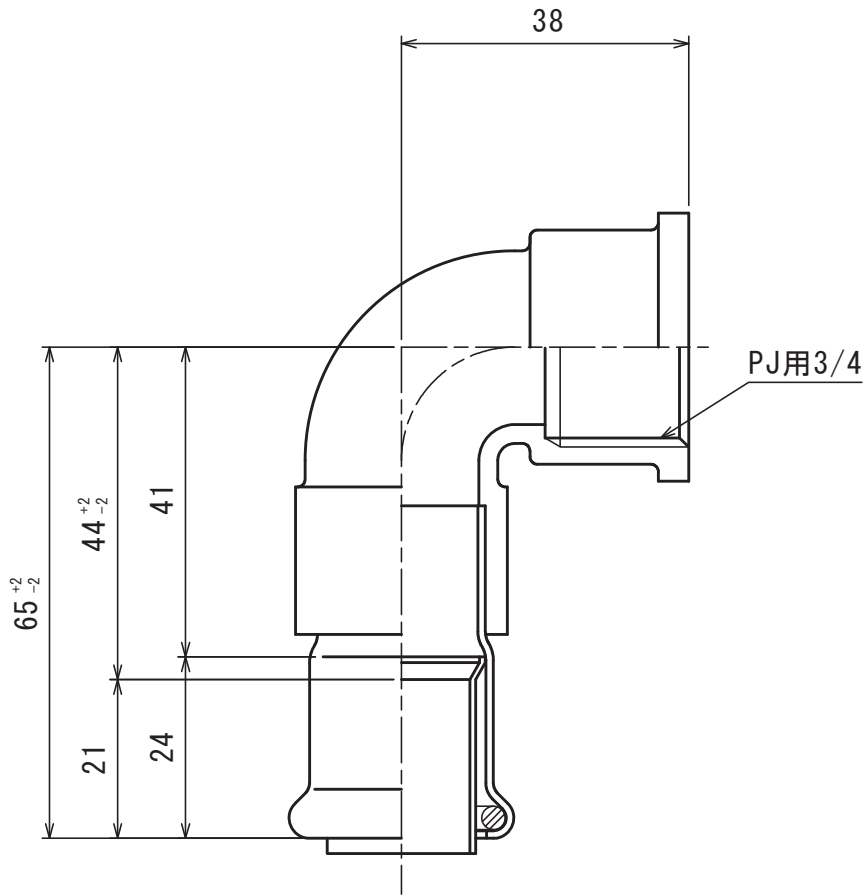

ALL DIMENSIONS ARE IN MILLIMETERS.

尺度 SCALE		品名 DESCRIPTION		3	寸法表記の見直し 寸法記号の見直し 寸法見直し	H23.04.04 H20.02.05 H14.02.20	山藤 谷藤 山藤
N. T. S		CUプレス ろう付タイプ 水栓エルボ20A×3/4		2			
発行 ISSUED BY	作成 PREPARED BY			1			
垣上	山藤	寸法 DIMENSIONAL	規格 STANDARD	図面番号 DRAWING No.		Rev. No. — 3	
				ZA4-030			

株式会社ベンカン・ジャパン

受注番号 Order No.		材料 Material	BC6 C1220T	数量 Quantity	
-------------------	--	----------------	---------------	----------------	--

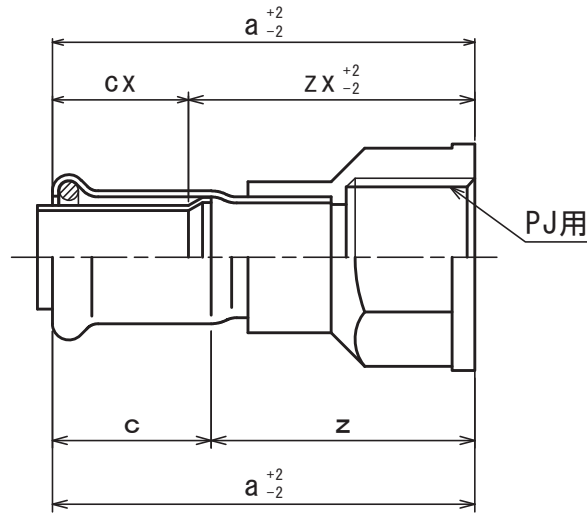

記号 サイズ(A)	a	z	c	ZX	CX	PJ用	
						呼び	ねじ山数 (25.4mm)
15x1/2	56	35	21	38	18	1/2	14
20x1/2	62	38	24	41	21	1/2	14
20x3/4	65	41	24	44	21	3/4	14

ALL DIMENSIONS ARE IN MILLIMETERS.

尺度 SCALE		品名 DESCRIPTION		3	寸法表記の見直し 寸法記号の見直し 水栓7が「7」に変更	H23.04.04 H20.02.05 H15.06.27	山藤 谷藤 山藤
N. T. S		CUプレス ろう付タイプ 水栓ソケット 15, 20A		2			
発行 ISSUED BY	作成 PREPARED BY			1			
垣上	山藤			寸法 DIMENSIONAL	規格 STANDARD	図面番号 DRAWING No.	
						ZA4-043	
						Rev. No. — 3	

株式会社ベンカン・ジャパン

受注番号 Order No.		材料 Material	BC6 C1220T	数量 Quantity	
-------------------	--	----------------	---------------	----------------	--

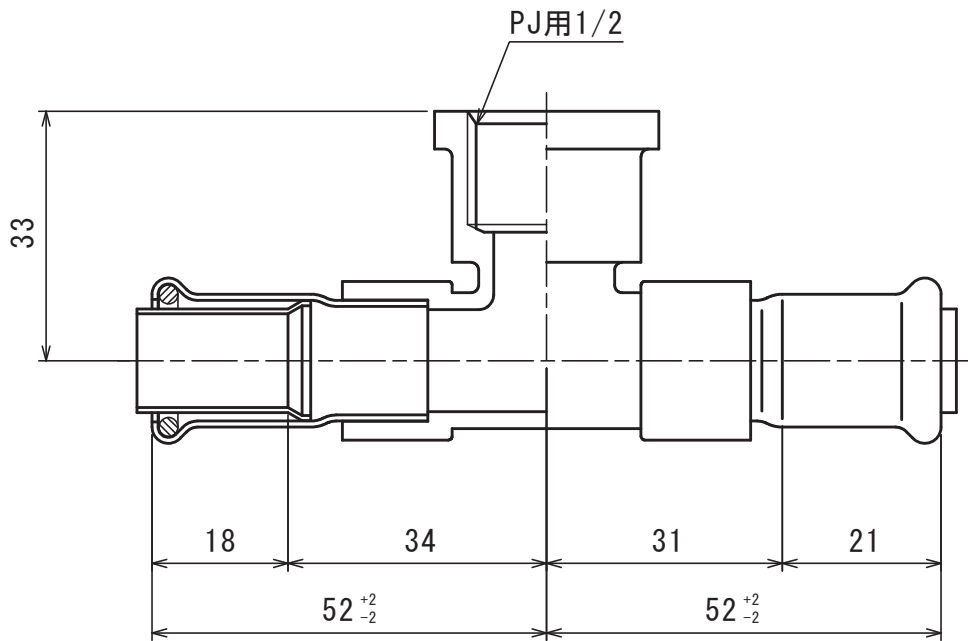

ALL DIMENSIONS ARE IN MILLIMETERS.

尺度 SCALE		品名 DESCRIPTION					
N. T. S		CUプレス ろう付タイプ 水栓ティー 15A×1/2		2	寸法表記の見直し 寸法記号の見直し	H23.04.04	山藤
発行 ISSUED BY	作成 PREPARED BY			改訂 Rev.		改訂内容 DESCRIPTION	発行 ISSUED BY
垣上	山藤	寸法 DIMENSIONAL	規格 STANDARD	図面番号 DRAWING No.		Rev. No. — 2	
				ZA4-072			

株式会社ベンカン・ジャパン

受注番号 Order No.		材料 Material	BC6 C1220T	数量 Quantity	
-------------------	--	----------------	---------------	----------------	--

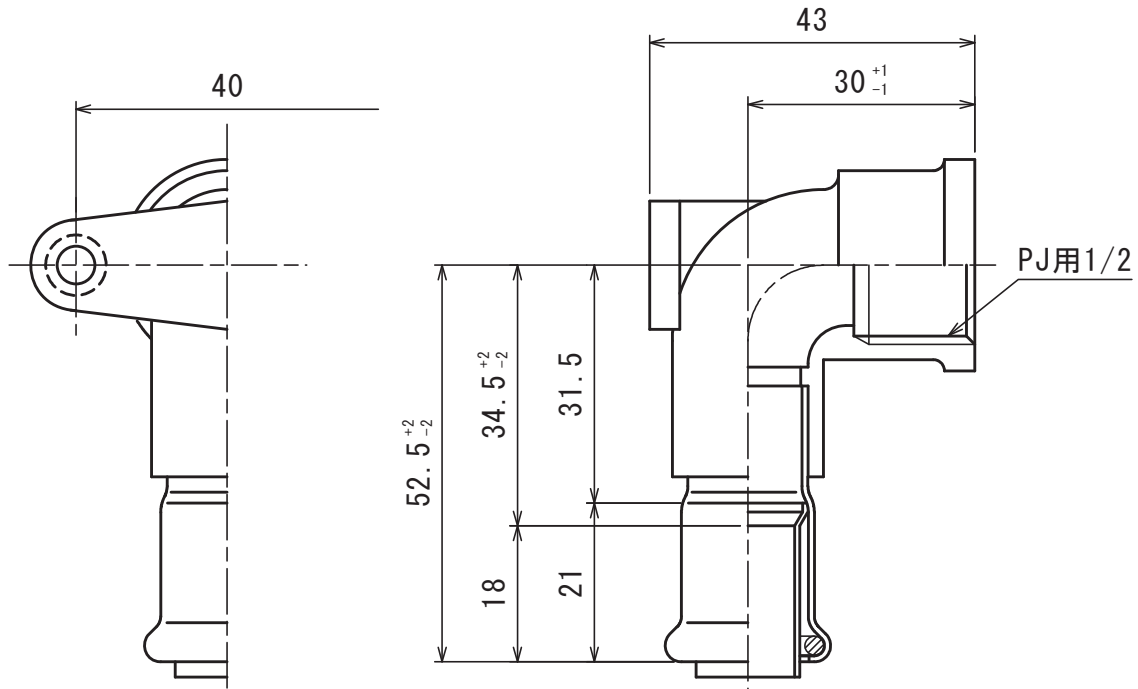
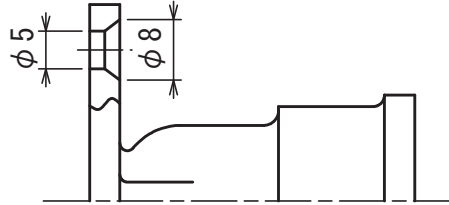

ALL DIMENSIONS ARE IN MILLIMETERS.

尺度 SCALE		品名 DESCRIPTION					
N. T. S		CUプレス ろう付タイプ 座付水栓エルボ 15A x 1/2		2 1	寸法表記の見直し 寸法記号の見直し	H23.04.04 H20.02.05	山藤 谷藤
発行 ISSUED BY	作成 PREPARED BY	改訂 Rev.	改訂内容 DESCRIPTION	発行 ISSUED BY	作成 PREPARED BY		
垣上	山藤	寸法 DIMENSIONAL	規格 STANDARD	図面番号 DRAWING No.		Rev. No. — 2	
				ZA4-033			

受注番号 Order No.		材料 Material	BC6 C1220T	数量 Quantity	
-------------------	--	----------------	---------------	----------------	--

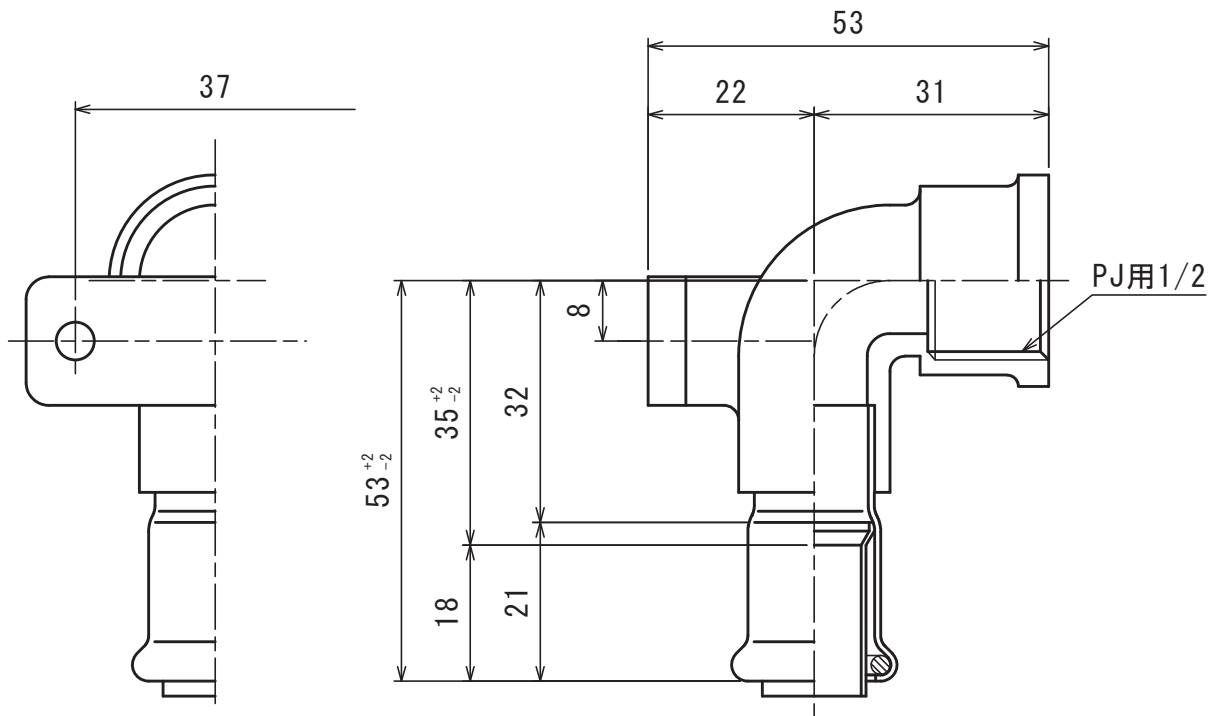
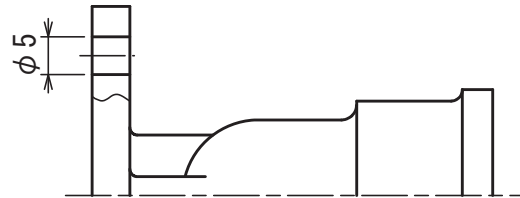

ALL DIMENSIONS ARE IN MILLIMETERS.

尺度 SCALE		品名 DESCRIPTION		3	寸法表記の見直し 寸法記号の見直し 水栓アダプタ寸法変更	H23.04.04 H20.02.05 H16.06.10	山藤 谷藤 山藤
N. T. S		CUプレス ろう付タイプ 座付水栓エルボ(腰高) 15A×1/2		2			
発行 ISSUED BY	作成 PREPARED BY	改訂 Rev.	改訂内容 DESCRIPTION	発行 ISSUED BY			
垣上	山藤	寸法 DIMENSIONAL	規格 STANDARD	図面番号 DRAWING No.		Rev. No. — 3	
				ZA4-046			

受注番号 Order No.		材料 Material	BC6 C1220T	数量 Quantity	
-------------------	--	----------------	---------------	----------------	--

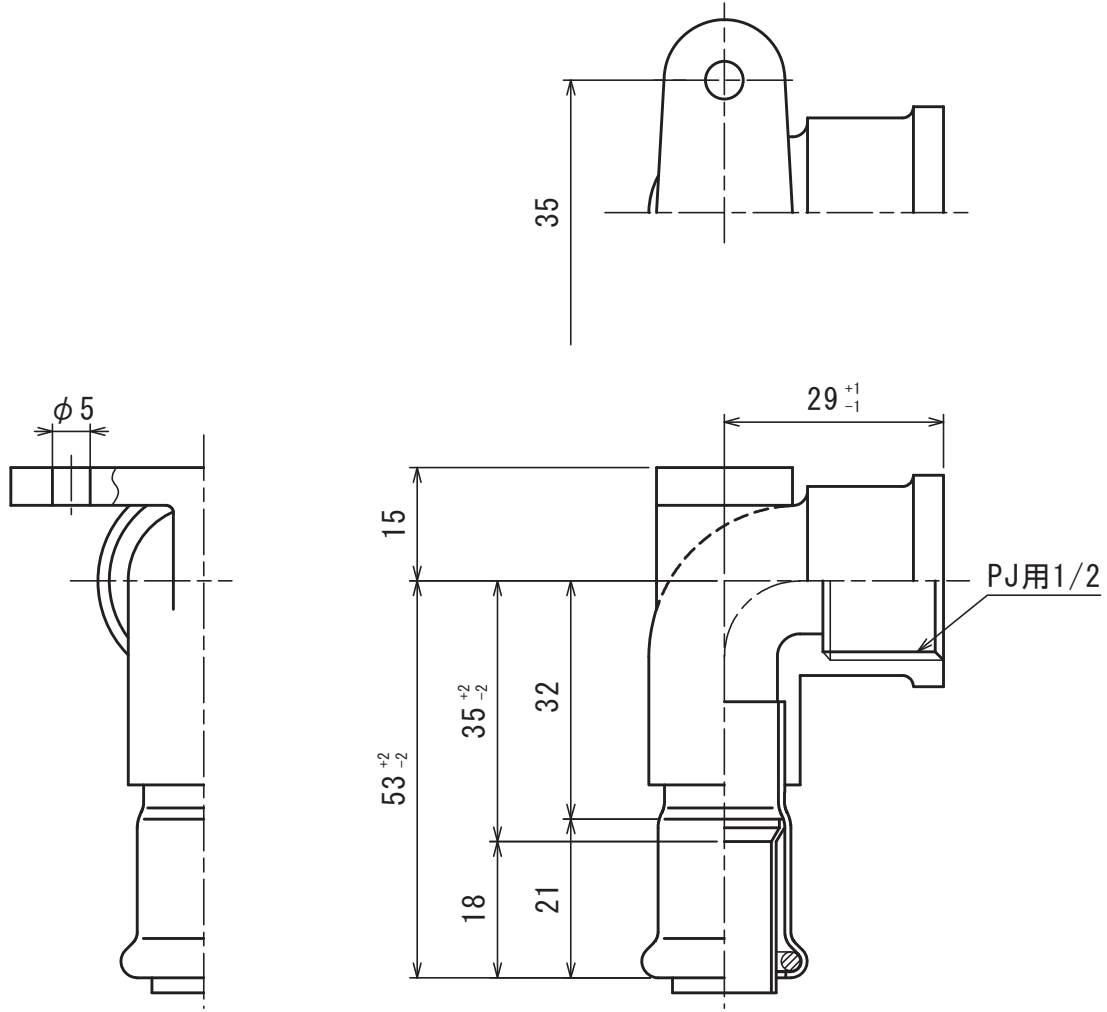

ALL DIMENSIONS ARE IN MILLIMETERS.

尺度 SCALE		品名 DESCRIPTION		3	寸法表記の見直し 寸法記号の見直し 水栓アダプタ寸法変更	H23.04.04 H20.02.05 H16.06.10	山藤 谷藤 山藤
N. T. S		CUプレス ろう付タイプ 逆座付水栓エルボ 15A×1/2		2			
発行 ISSUED BY	作成 PREPARED BY			1			
		改訂 Rev.	改訂内容 DESCRIPTION	発行 ISSUED BY	作成 PREPARED BY		
垣上	山藤	寸法 DIMENSIONAL	規格 STANDARD	図面番号 DRAWING No.		Rev. No. — 3	
				ZA4-063			

受注番号 Order No.		材料 Material	BC6 C1220T	数量 Quantity	
-------------------	--	----------------	---------------	----------------	--

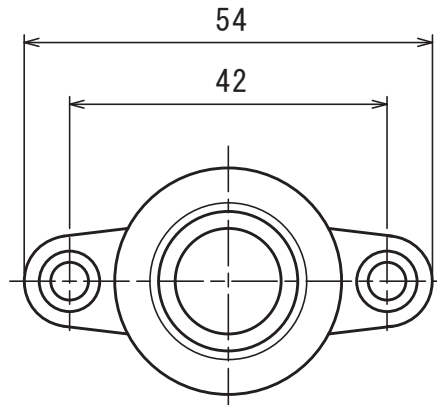
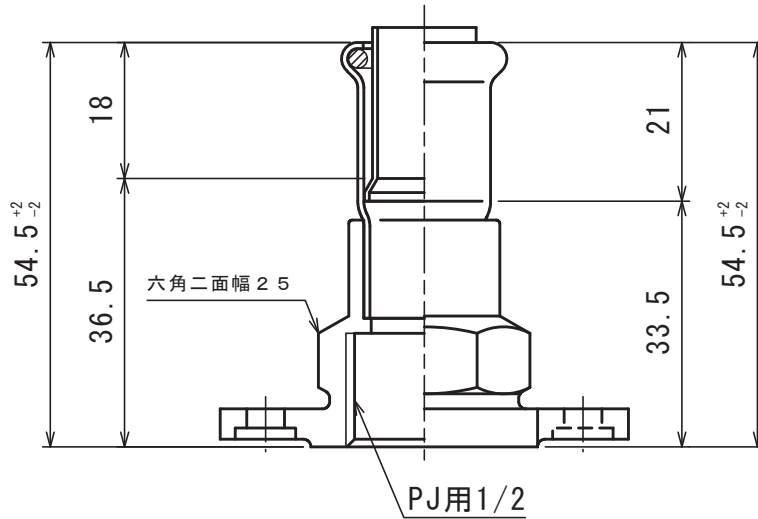

ALL DIMENSIONS ARE IN MILLIMETERS.

尺度 SCALE		品名 DESCRIPTION					
N. T. S		CUプレス ろう付タイプ		2	寸法表記の見直し	H23.04.04	山藤
発行 ISSUED BY	作成 PREPARED BY	座付水栓ソケット 15A×1/2		改訂 Rev.	改訂内容 DESCRIPTION	発行 ISSUED BY	作成 PREPARED BY
垣上	山藤	寸法 DIMENSIONAL	規格 STANDARD	図面番号 DRAWING No.			
				ZA4-060			Rev. No. — 2

株式会社ベンカン・ジャパン

受注番号 Order No.		材料 Material	BC6 C1220T	数量 Quantity	
-------------------	--	----------------	---------------	----------------	--

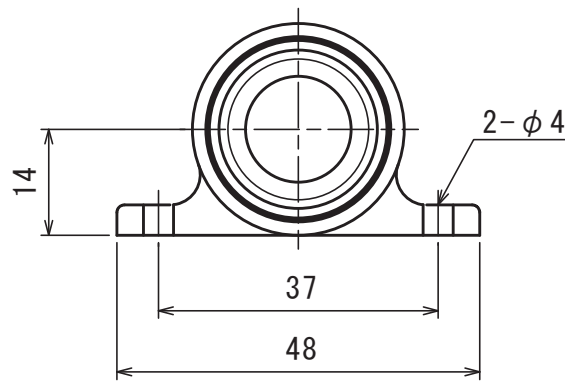
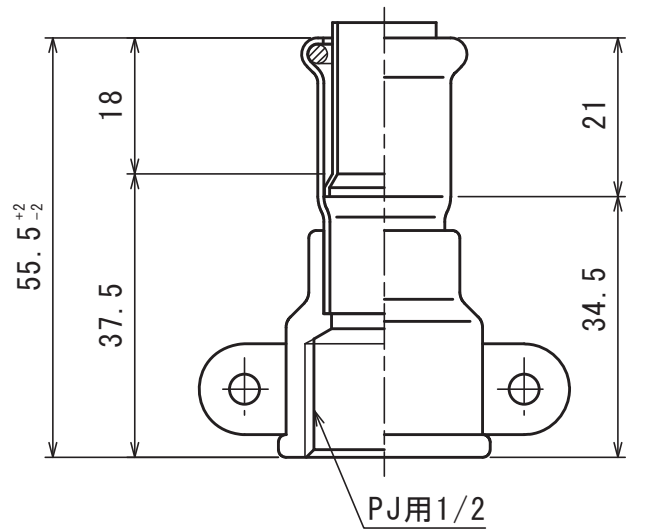

ALL DIMENSIONS ARE IN MILLIMETERS.

尺度 SCALE		品名 DESCRIPTION					
N. T. S		CUプレス ろう付タイプ		2	寸法表記の見直し 寸法記号の見直し	H23.04.04 H20.02.05	山藤 谷藤
発行 ISSUED BY	作成 PREPARED BY	逆座付水栓ソケット 15A×1/2		改訂 Rev.			
垣上	山藤			寸法 DIMENSIONAL	規格 STANDARD	図面番号 DRAWING No.	
						ZA4-064	
						Rev. No. — 2	

受注番号 Order No.		材料 Material	BC6 C1220T	数量 Quantity	
-------------------	--	----------------	---------------	----------------	--

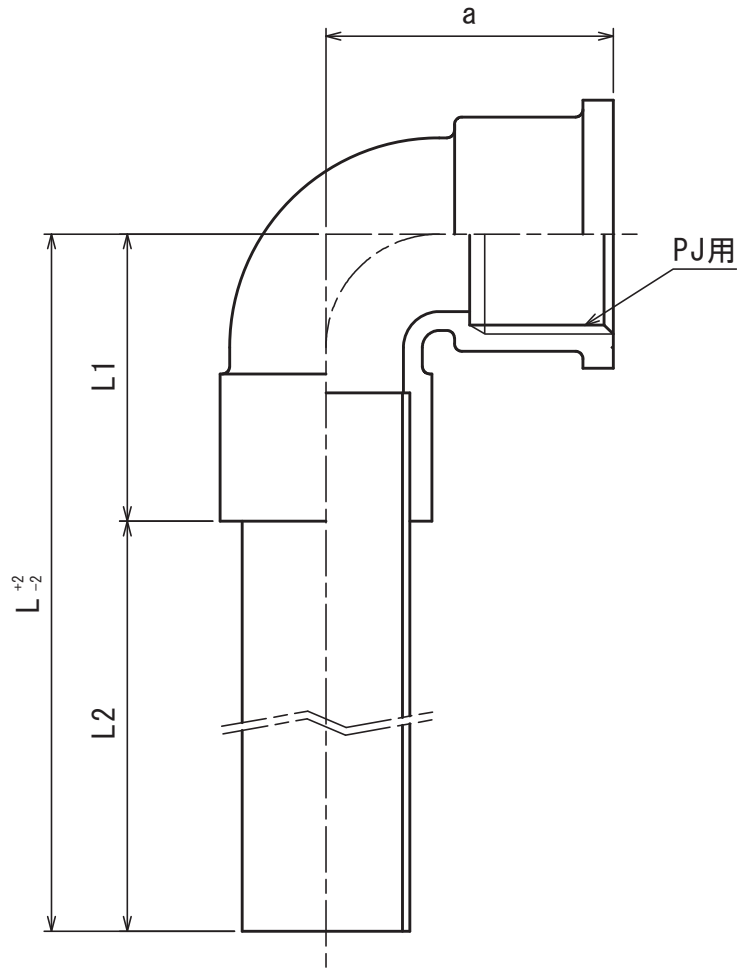

記号 サイズ(A)	a	L	L1	L2	PJ用	パイプ MタイプH材
					呼び	
15x1/2	30	128	28	100	1/2	15A
20x1/2	38	136	36	100	1/2	20A
20x3/4	38	138	38	100	3/4	20A

ALL DIMENSIONS ARE IN MILLIMETERS.

尺度 SCALE		品名 DESCRIPTION		3	寸法表記の見直し 寸法記号の見直し 図番変更	H23.04.04 H20.02.05 H14.02.20	山藤 谷藤 山藤	
N. T. S		CUプレス ろう付タイプ 水栓エルボ直管付 15, 20A		2				
発行 ISSUED BY	作成 PREPARED BY			1				改訂 Rev.
垣上	山藤			寸法 DIMENSIONAL	規格 STANDARD	図面番号 DRAWING No.		
						ZA4-056		Rev. No. — 3

受注番号 Order No.		材料 Material	BC6 C1220T	数量 Quantity	
-------------------	--	----------------	---------------	----------------	--

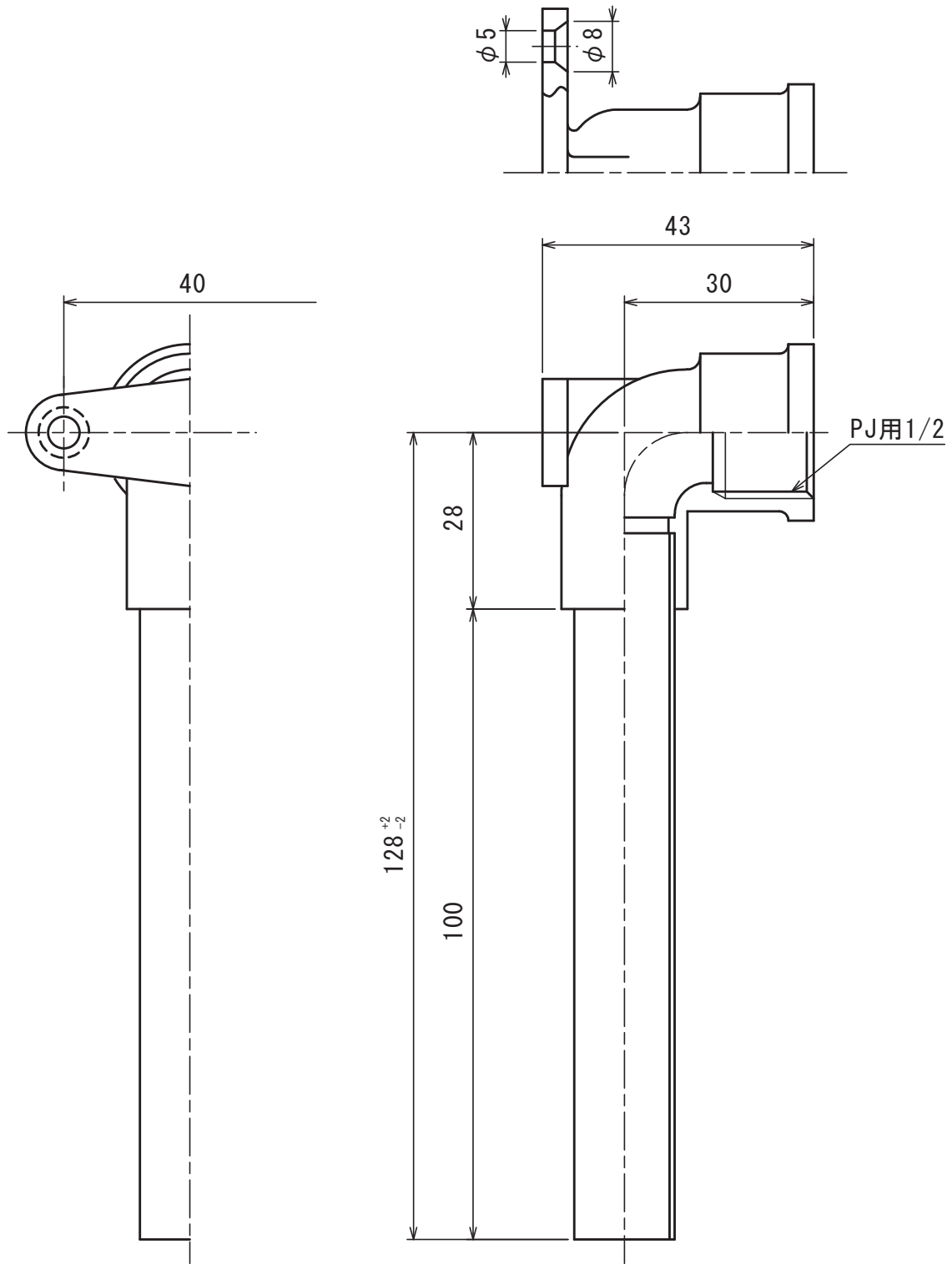

ALL DIMENSIONS ARE IN MILLIMETERS.

尺度 SCALE		品名 DESCRIPTION		3	寸法表記の見直し 寸法記号の見直し 図番変更	H23.04.04 H20.02.05 H14.02.20	山藤 谷藤 山藤
N. T. S		CUプレス ろう付タイプ 座付水栓エルボ直管付 15A×1/2		2			
発行 ISSUED BY	作成 PREPARED BY			1			
垣上	山藤	寸法 DIMENSIONAL	規格 STANDARD	図面番号 DRAWING No.		Rev. No. — 3	
				ZA4-059			

株式会社ベンカン・ジャパン

受注番号 Order No.		材料 Material	C3604 C1220T	数量 Quantity	
-------------------	--	----------------	-----------------	----------------	--

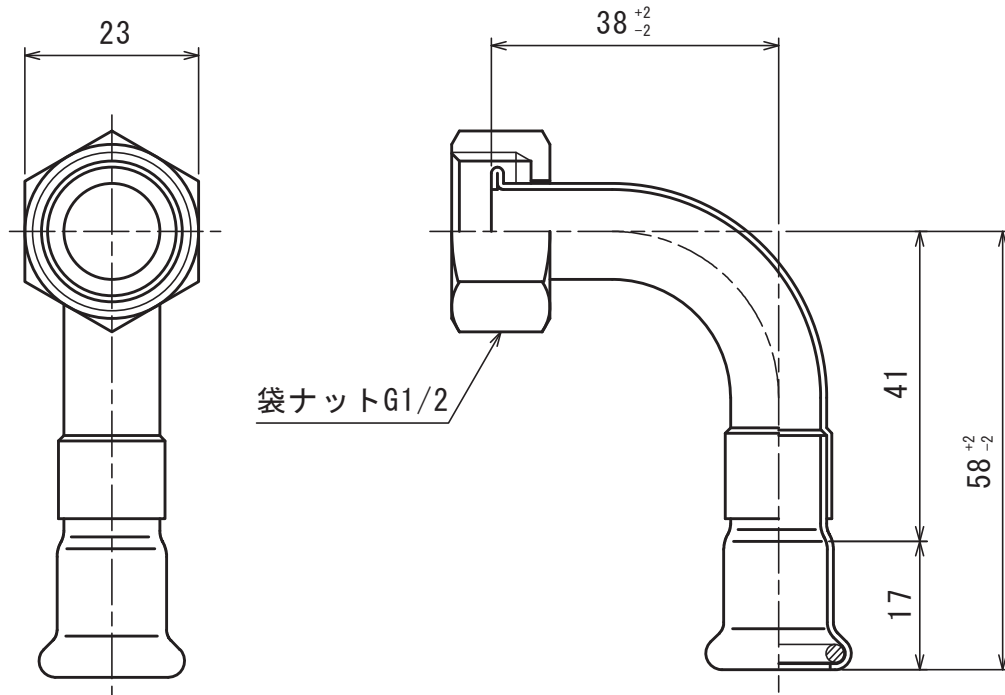

ALL DIMENSIONS ARE IN MILLIMETERS.

尺度 SCALE		品名 DESCRIPTION					
N. T. S		CUプレス ろう付タイプ 90°ユニオン 10A×1/2		1	寸法記号の見直し	H20.02.05	谷藤
発行 ISSUED BY	作成 PREPARED BY	改訂 Rev.	改訂内容 DESCRIPTION	発行 ISSUED BY	作成 PREPARED BY		
勅使川原	山藤	寸法 DIMENSIONAL	規格 STANDARD	図面番号 DRAWING No.		Rev. No.	
				ZA4-054		— 1	

株式会社ベンカン・ジャパン

受注番号 Order No.		材料 Material	C3604 C1220T	数量 Quantity	
-------------------	--	----------------	-----------------	----------------	--

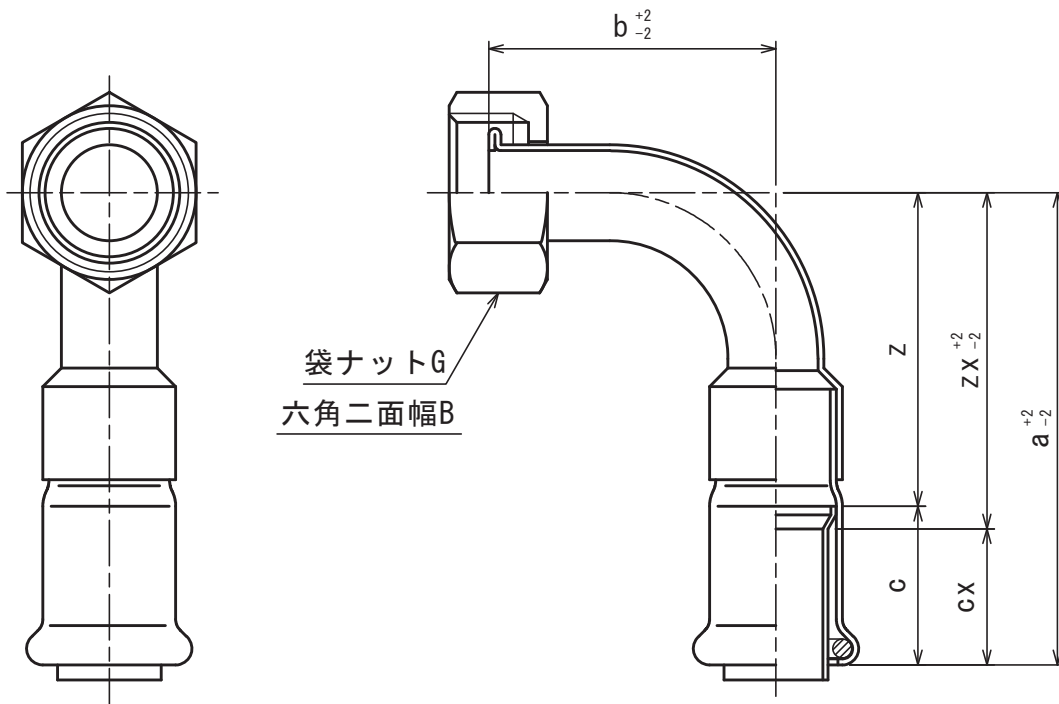

記号 サイズ(A)	a	b	z	c	zx	cx	B	G 呼び
	15x1/2	62.5	38	41.5	21	44.5	18	23
15x3/4	65.5	41	44.5	21	47.5	18	29	3/4
20x1/2	68	41	44	24	47	21	23	1/2
20x3/4	75	48	51	24	54	21	29	3/4

ALL DIMENSIONS ARE IN MILLIMETERS.

尺度 SCALE		品名 DESCRIPTION		1 寸法記号の見直し		H20.02.05 谷藤	
N. T. S		CUプレス ろう付タイプ 90°ユニオン 15, 20A		改訂 Rev.		改訂内容 DESCRIPTION	
発行 ISSUED BY	作成 PREPARED BY			寸法規格 DIMENSIONAL STANDARD		図面番号 DRAWING No.	
勅使川原	山藤					ZA4-035 Rev. No. 1	

株式会社ベンカン・ジャパン

受注番号 Order No.		材料 Material	C3604 C1220T	数量 Quantity	
-------------------	--	----------------	-----------------	----------------	--

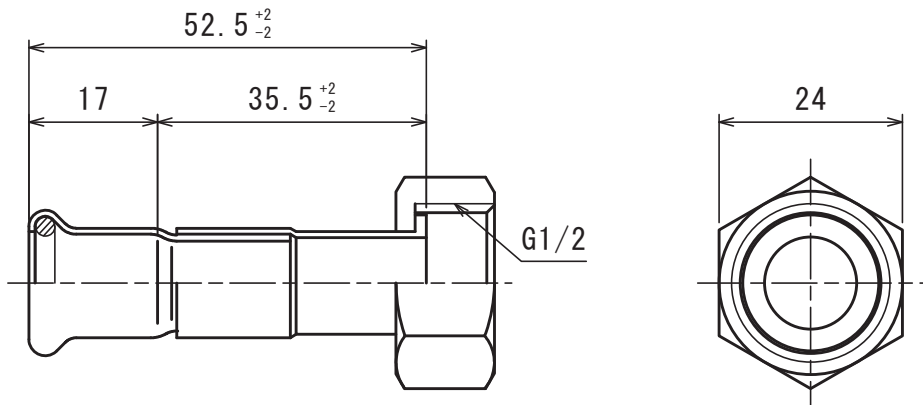

ALL DIMENSIONS ARE IN MILLIMETERS.

尺 度 SCALE		品 名 DESCRIPTION					
N. T. S		CUプレス ろう付タイプ		1	寸法記号の見直し	H20.02.05	谷藤
発行 ISSUED BY	作成 PREPARED BY	ユニオンソケット 10A×1/2		改訂 Rev.	改訂内容 DESCRIPTION	発行 ISSUED BY	作成 PREPARED BY
勅使川原	山藤	寸法 DIMENSIONAL	規格 STANDARD	図面番号 DRAWING No.		Rev. No.	
				ZA4-053		— 1	

受注番号 Order No.		材料 Material	C3604 C1220T	数量 Quantity	
-------------------	--	----------------	-----------------	----------------	--

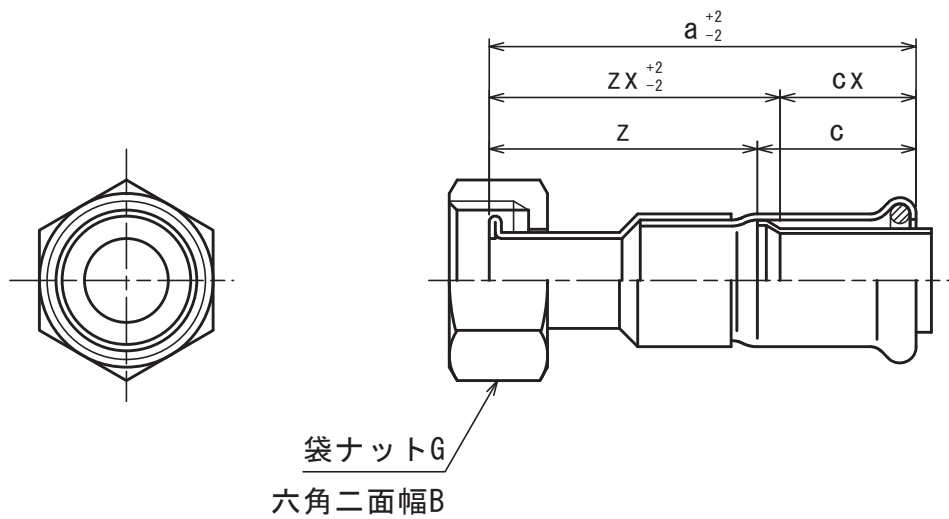

記号 サイズ(A)	a	z	c	zx	cx	B	G
							呼び
15x1/2	56.5	35.5	21	38.5	18	23	1/2
15x3/4	57	36	21	39	18	29	3/4
20x1/2	68	44	24	47	21	23	1/2
20x3/4	65	41	24	44	21	29	3/4

ALL DIMENSIONS ARE IN MILLIMETERS.

尺度 SCALE		品名 DESCRIPTION						
N. T. S		CUプレス ろう付タイプ ユニオンソケット 15, 20A		1 寸法記号の見直し		H20.02.05 谷藤		
発行 ISSUED BY	作成 PREPARED BY			改訂 Rev.	改訂内容 DESCRIPTION		発行 ISSUED BY	作成 PREPARED BY
勅使川原	山藤			寸法規格 DIMENSIONAL STANDARD		図面番号 DRAWING No.		
						ZA4-039		
						Rev. No. 1		

株式会社ベンカン・ジャパン

受注番号 Order No.		材料 Material	BC6 C1220T	数量 Quantity	
-------------------	--	----------------	---------------	----------------	--

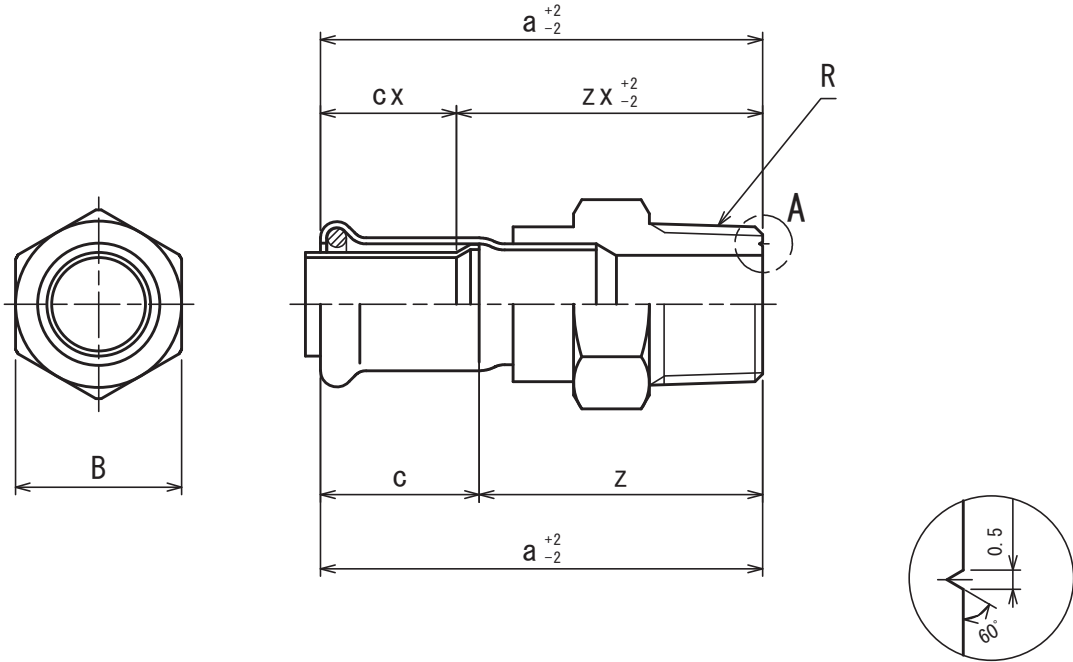

A詳細

記号 サイズ(A)	a	z	c	ZX	cX	B	R	
							呼び	ねじ山数 (25.4mm)
15 × 1/2	58.5	37.5	21	40.5	18	22	1/2	14

ALL DIMENSIONS ARE IN MILLIMETERS.

尺度 SCALE		品名 DESCRIPTION					
N. T. S		CUプレス ろう付タイプ 平パッキン用 雄アダプタ付ソケット 15A×1/2		1	寸法記号の見直し	H20.02.05	谷藤
発行 ISSUED BY	作成 PREPARED BY			改訂 Rev.	改訂内容 DESCRIPTION	発行 ISSUED BY	作成 PREPARED BY
勅使川原	山藤			寸法 DIMENSIONAL	規格 STANDARD	図面番号 DRAWING No.	
						ZA4-065	
						Rev. No. — 1	

受注番号 Order No.		材料 Material	BC6 C1220T	数量 Quantity	
-------------------	--	----------------	---------------	----------------	--

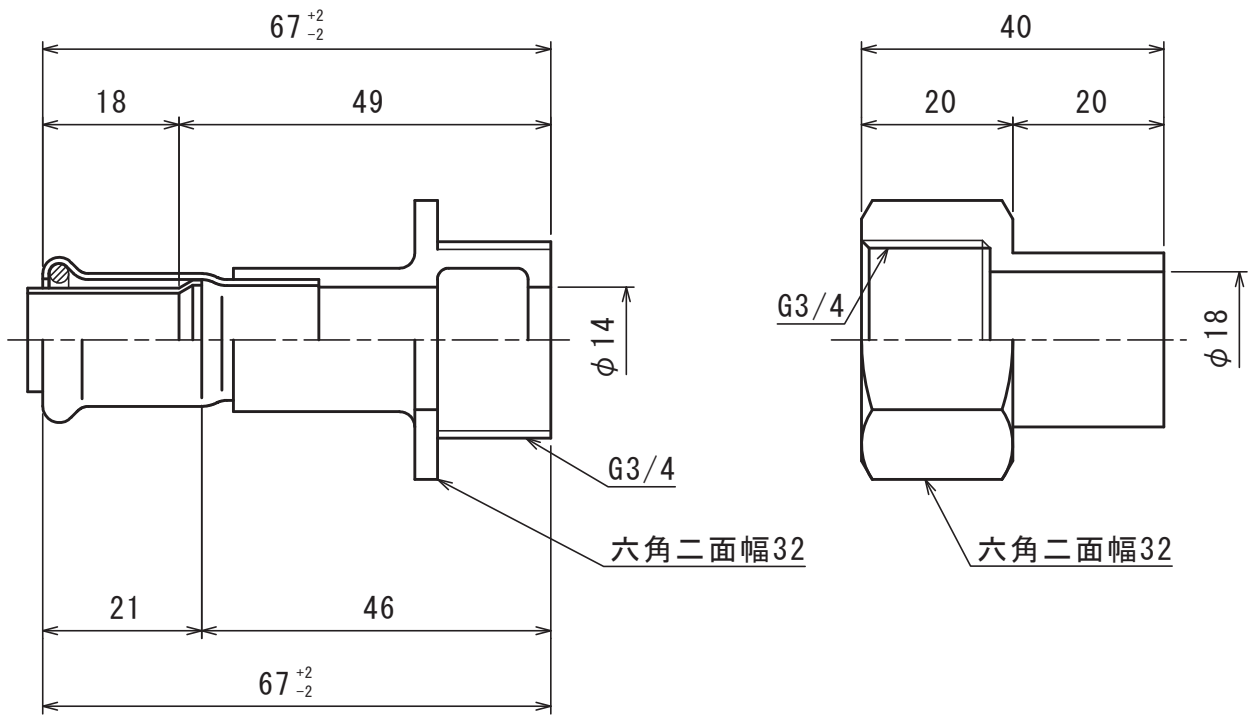

ALL DIMENSIONS ARE IN MILLIMETERS.

尺度 SCALE		品名 DESCRIPTION					
N. T. S		CUプレス ろう付タイプ 塩ビ管用シモク 15A×13		1	寸法記号の見直し	H20.02.05	谷藤
発行 ISSUED BY	作成 PREPARED BY	改訂 Rev.	改訂内容 DESCRIPTION	発行 ISSUED BY	作成 PREPARED BY		
勅使川原	山藤	寸法 DIMENSIONAL	規格 STANDARD	図面番号 DRAWING No.		Rev. No.	
				ZA4-066		— 1	

受注番号 Order No.		材料 Material	BC6 C1220T	数量 Quantity	
-------------------	--	----------------	---------------	----------------	--

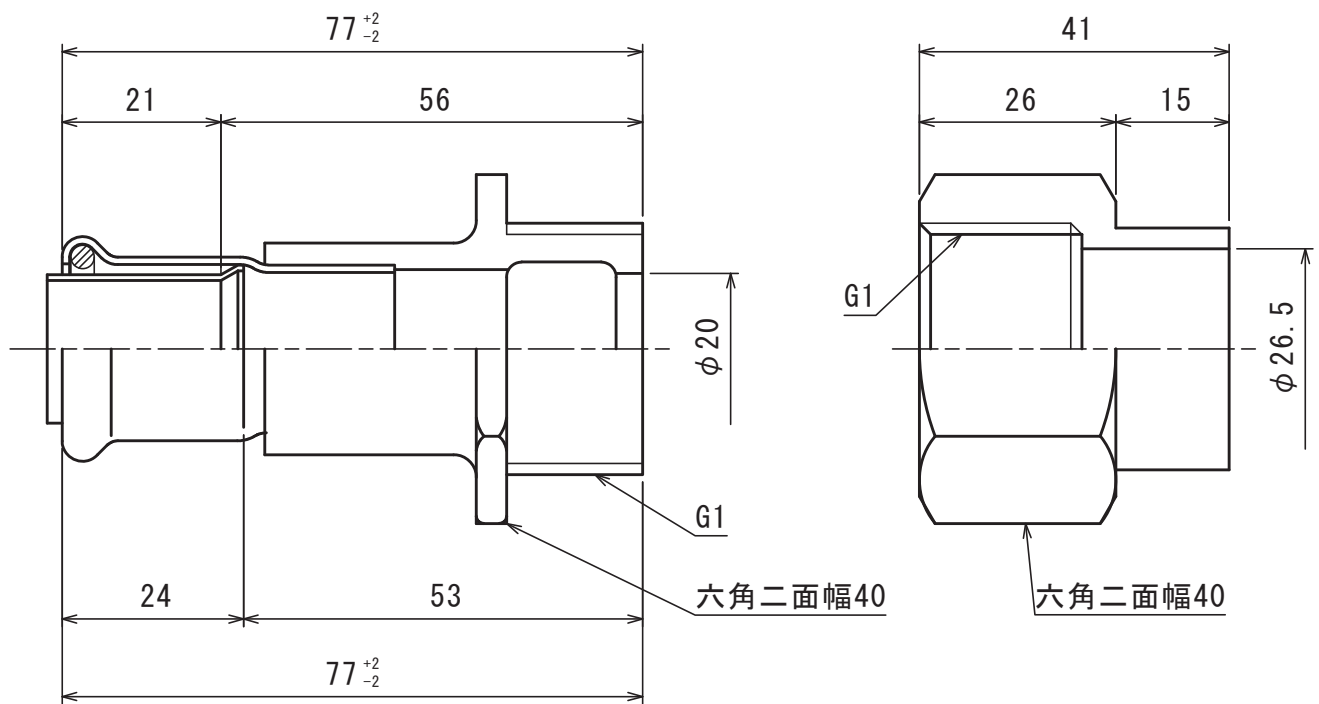

ALL DIMENSIONS ARE IN MILLIMETERS.

尺度 SCALE		品名 DESCRIPTION					
N. T. S		CUプレス ろう付タイプ 塩ビ管用シモク 20A×20		1	寸法記号の見直し	H20.02.05	谷藤
発行 ISSUED BY	作成 PREPARED BY	改訂 Rev.	改訂内容 DESCRIPTION	発行 ISSUED BY	作成 PREPARED BY		
勅使川原	山藤	寸法 DIMENSIONAL	規格 STANDARD	図面番号 DRAWING No.			
				ZA4-067		Rev. No. — 1	

株式会社ベンカン・ジャパン

受注番号 Order No.		材料 Material	C1220T	数量 Quantity	
-------------------	--	----------------	--------	----------------	--

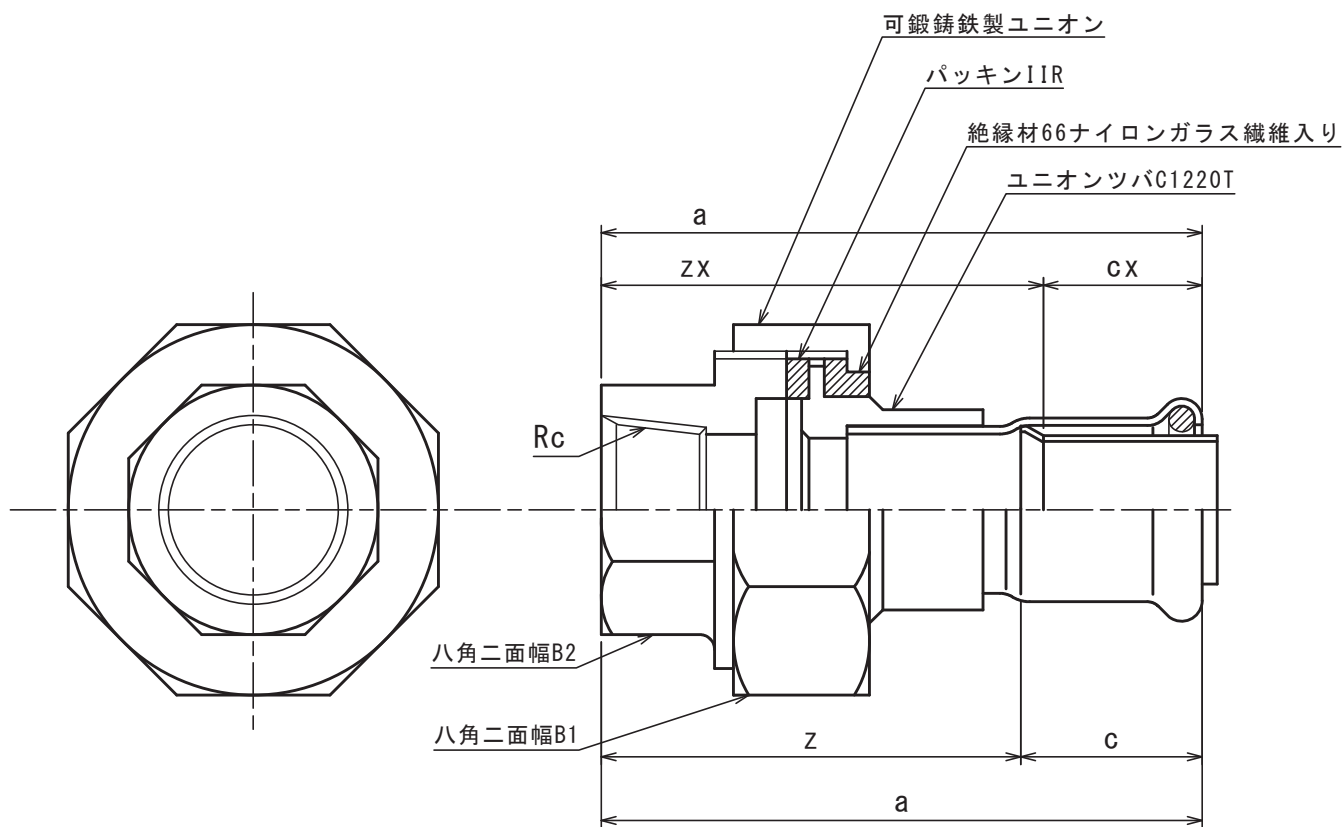

記号 サイズ(A)	a	z	c	zx	cx	B1	B2	Rc	
								呼び	ネジ山数 (25.4mmにつき)
15	70	49	21	52	20	42	27	1/2	14
20	81	57	24	60	23	49	33	3/4	14

注意

ユニオン部はF型ユニオンとし、外面は亜鉛メッキ及び樹脂コーティング仕上げとする。

ALL DIMENSIONS ARE IN MILLIMETERS.

尺度 SCALE		品名 DESCRIPTION							
N. T. S		CUプレス ろう付タイプ		1 寸法記号の見直し		H20.02.06		谷藤	
発行 ISSUED BY	作成 PREPARED BY	絶縁ユニオン 15, 20A		改訂 Rev.	改訂内容 DESCRIPTION	発行 ISSUED BY	作成 PREPARED BY		
勅使川原	山藤			寸法規格 DIMENSIONAL STANDARD		図面番号 DRAWING No.			
						ZA4-055			
								Rev. No. 1	

受注番号 Order No.		材料 Material	C3771 C1220T	数量 Quantity	
-------------------	--	----------------	-----------------	----------------	--

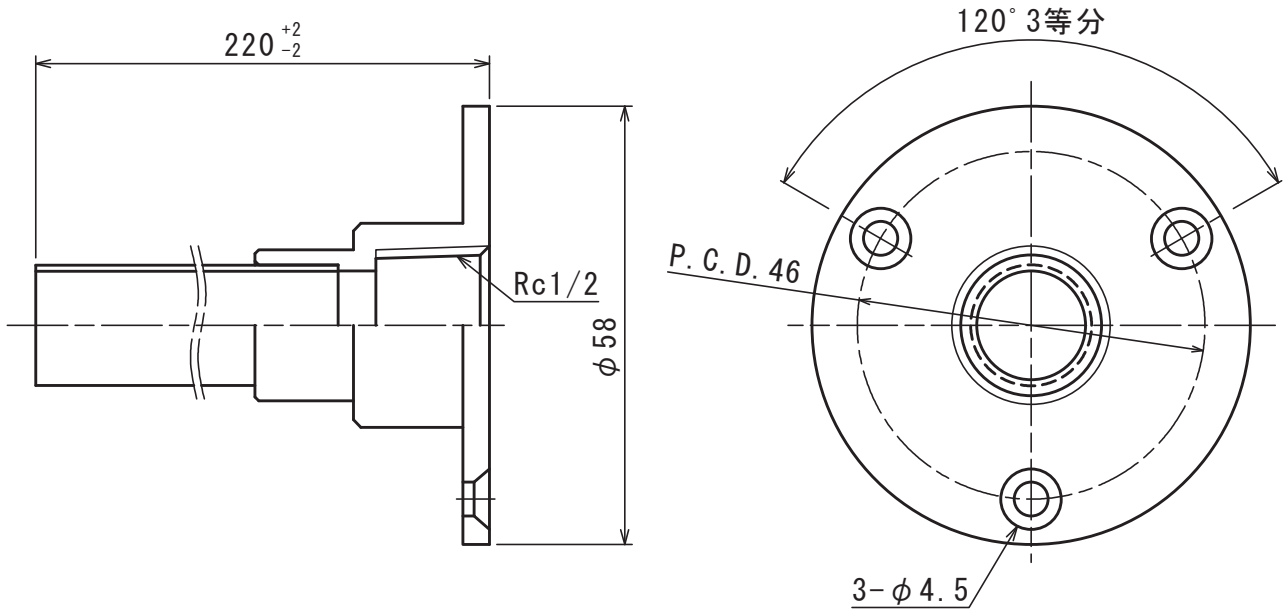

ALL DIMENSIONS ARE IN MILLIMETERS.

尺度 SCALE		品名 DESCRIPTION					
N. T. S		CUプレス ろう付タイプ 直管付ザルボ 15A x 1/2		2 1		寸法記号の見直し	
発行 ISSUED BY	作成 PREPARED BY			改訂 Rev.	改訂内容 DESCRIPTION	発行 ISSUED BY	作成 PREPARED BY
勅使川原	山藤			寸法 DIMENSIONAL	規格 STANDARD	図面番号 DRAWING No.	
						ZA4-068	
						Rev. No. — 2	

受注番号 Order No.		材料 Material	C3771 C1220T	数量 Quantity	
-------------------	--	----------------	-----------------	----------------	--

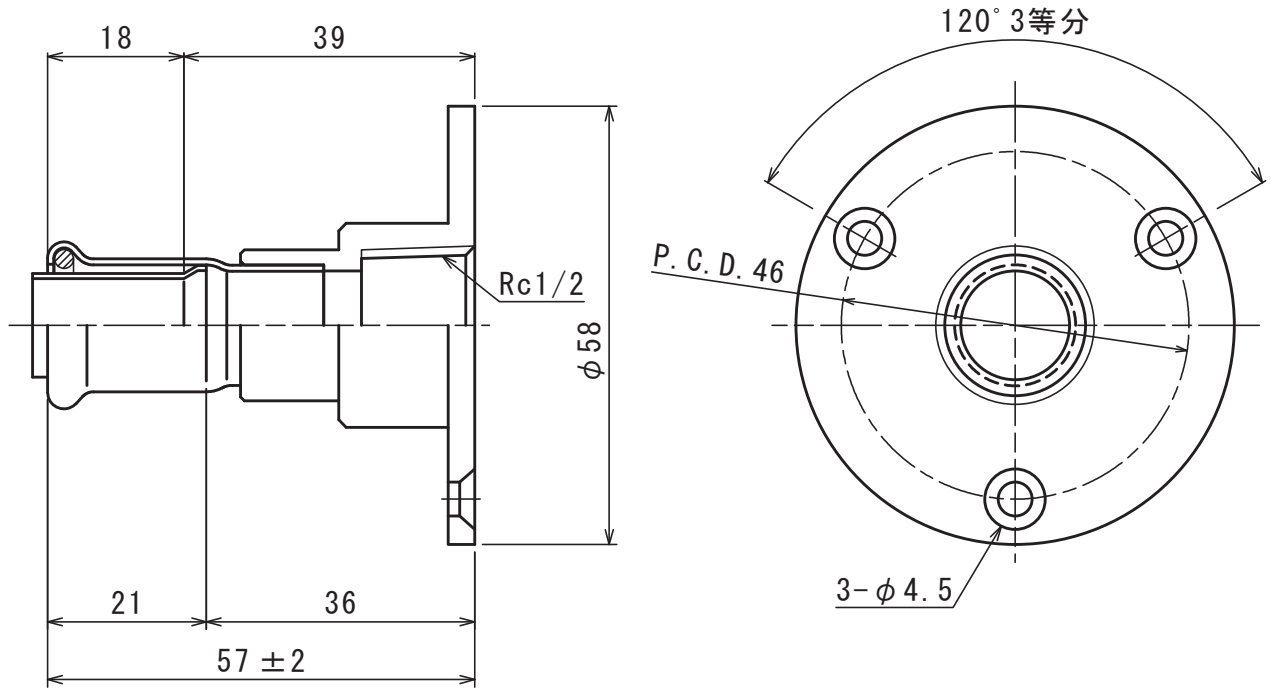

ALL DIMENSIONS ARE IN MILLIMETERS.

尺度 SCALE		品名 DESCRIPTION					
N. T. S		CUプレス ろう付タイプ 片ソケット付ザルボ 15A×1/2		2 1		H22.11.09 H20.02.06	
発行 ISSUED BY	作成 PREPARED BY			改訂 Rev.	改訂内容 DESCRIPTION	発行 ISSUED BY	作成 PREPARED BY
勅使川原	山藤			寸法 DIMENSIONAL	規格 STANDARD	図面番号 DRAWING No.	
						ZA4-069	
						Rev. No. — 2	

株式会社ベンカン・ジャパン

受注番号 Order No.		材料 Material	BC6 C1220T	数量 Quantity	
-------------------	--	----------------	---------------	----------------	--

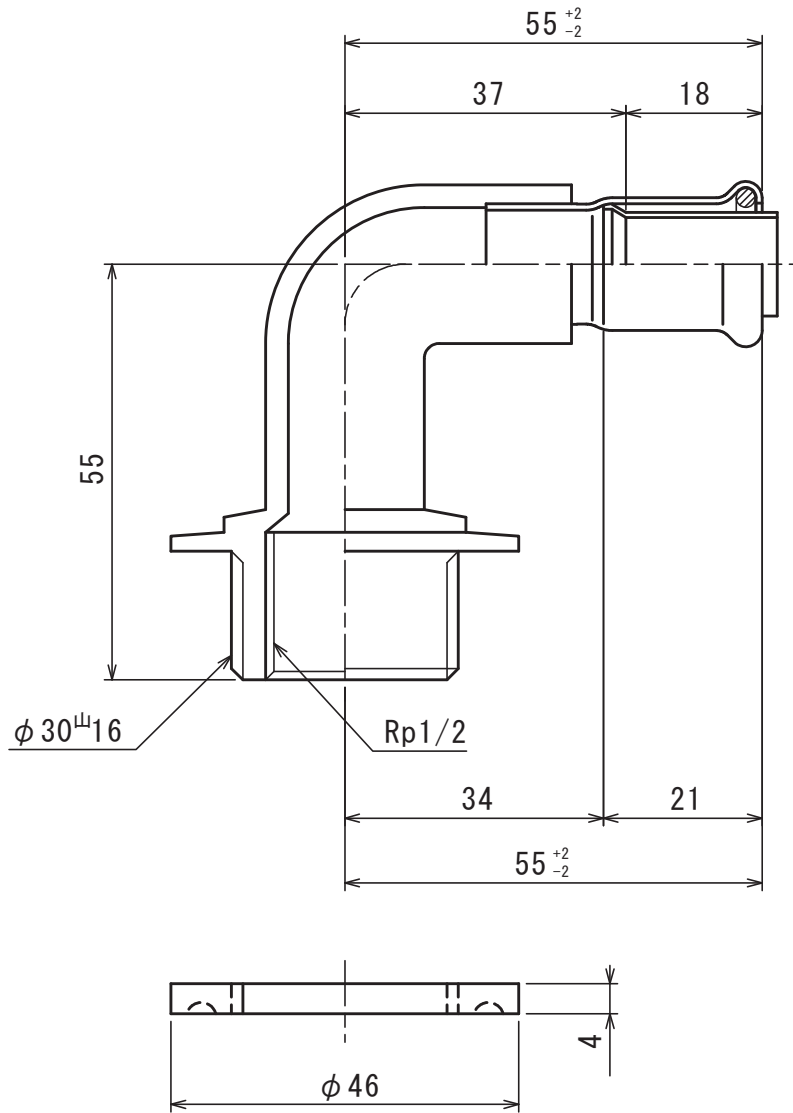

ALL DIMENSIONS ARE IN MILLIMETERS.

尺度 SCALE		品名 DESCRIPTION					
N. T. S		CUプレス ろう付タイプ 送り座付水栓エルボ 15A x 1/2		2 1	寸法記号の見直し 誤記訂正	H20.02.05 H14.05.01	谷藤 山藤
発行 ISSUED BY	作成 PREPARED BY			改訂 Rev.	改訂内容 DESCRIPTION	発行 ISSUED BY	作成 PREPARED BY
勅使 川原	山 藤			寸法 DIMENSIONAL	規格 STANDARD	図面 DRAWING	
						番号 No.	
						ZA4-061	
						Rev. No. — 2	

株式会社ベンカン・ジャパン

受注番号 Order No.		材料 Material	BC6 C1220T	数量 Quantity	
-------------------	--	----------------	---------------	----------------	--

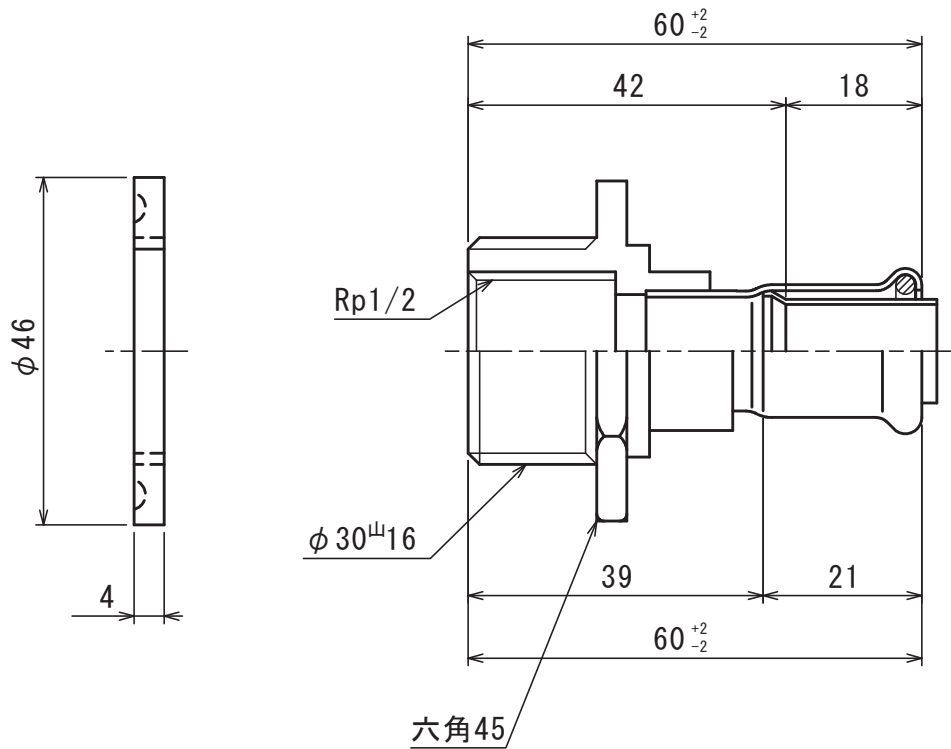

ALL DIMENSIONS ARE IN MILLIMETERS.

尺度 SCALE		品名 DESCRIPTION					
N. T. S		CUプレス ろう付タイプ 送り座付水栓ソケット 15A×1/2		2 1	寸法記号の見直し 誤記訂正	H20.02.05 H14.05.01	谷藤 山藤
発行 ISSUED BY	作成 PREPARED BY	改訂 Rev.	改訂内容 DESCRIPTION	発行 ISSUED BY	作成 PREPARED BY		
勅使 川原	山 藤	寸法 DIMENSIONAL	規格 STANDARD	図面 DRAWING		番号 No.	
				ZA4-062		Rev. No. — 2	

株式会社ベンカン・ジャパン